



CITY OF RIALTO CONTRACT CHANGE ORDER

To: Match Corporation
PO Box 10
Highland CA, 92346

Date: August 15, 2019
Project No: City Project No. 180804

Project: 2017/18 Annual Street Overlay
Project

Change Order No: 02
Purchase Order 2019-1221
Account 201-500-4310-3001-180804-35
Number(s): 202-500-4317-3001-180804-05
203-500-7305-3001-180804-45
223-500-4414-3001-180804-22

Attn: Jake Reade, Project Manager

CHANGES IN WORK:

This Contract Change Order No. 2 accommodates additional work, generally identified as:

CCO#2, item No. 1: Contract Change Order No. 2, Item 1: As directed by the City Engineer, Match Corporation is directed to construct City of Rialto Standard Plan SC-215 ADA ramp instead of the planned Caltrans Standard Plan ADA ramp A88A/A88B at the S/W/C of Sycamore and Rialto.

CCO#2, item No. 2: Contract Change Order No. 2, Item 2: As directed by the City Engineer, Match Corporation utilize 4000 PSI PCC for the construction of the driveways and adjacent curb/gutter along Valley Boulevard East.

CCO#2, item No. 3: Contract Change Order No. 2, Item 3: As directed by the City Engineer, Match Corporation is directed to make revisions to the original striping plans sheets 12 and 13 on Merrill Avenue.

CCO#2, item No. 4: Contract Change Order No. 2, Item 4: As directed by the City Engineer, Match Corporation is to install a reflective street name sign in lieu of the originally designated ISNS sign to be installed at Merrill and Cedar. This change was in response to the Contractor's RFI No. 2.

CCO#2, item No. 5: Contract Change Order No. 2, Item 5: As directed by the City Engineer, Match Corporation is to relocate previously placed project information signs from their original location to new locations designed by the field engineer.

CCO#2, item No. 6: Contract Change Order No. 2, Item 6: As directed by the City Engineer, Match Corporation is directed to perform additional pot-holing for the unmarked/unknown storm drain in Merrill Avenue.

CCO#2, item No. 7: Contract Change Order No. 2, Item 7: As directed by the City Engineer, Match Corporation is directed to perform additional saw-cutting of a previously saw-cut ADA ramp.

CCO#2, item No. 8: Contract Change Order No. 2, Item 8: As directed by the City Engineer, Match Corporation is directed to construct a new 3' ribbon gutter on Rialto Avenue behind an existing approach.

CCO#2, item No. 9: Contract Change Order No. 2, Item 9: As directed by the City Engineer, Matich Corporation is directed to construct a new 3' ribbon gutter on Rialto Avenue behind an existing approach.

CCO#2, item No. 10: Contract Change Order No. 2, Item 10: As directed by the City Engineer, Matich Corporation is directed to remove existing concrete curb and gutter and concrete sidewalk beyond the ECR at Merrill as directed by the field engineer.

CCO#2, item No. 11: Contract Change Order No. 2, Item 11: As directed by the City Engineer, Matich Corporation is directed to remove existing concrete and asphalt pavement at Station 15+65 on Rialto Avenue to accommodate the redesign of a driveway.

CCO#2, item No. 12: Contract Change Order No. 2, Item 12: As directed by the City Engineer, Matich Corporation is directed to repair a shallow water service damaged during the concrete removal process.

CCO#2, item No. 13: Contract Change Order No. 2, Item 13: As directed by the City Engineer, Matich Corporation is directed to saw-cut for an additional driveway on Valley at the P&S Truck Center.

CCO#2, item No. 14: Contract Change Order No. 2, Item 14: As directed by the City Engineer, Matich Corporation is directed to remove portions of a previously constructed ADA ramp at Southwest corner of Linden and Foothill to accommodate the City's redesign of the original ramp.

CCO#2, item No. 15: Contract Change Order No. 2, Item 15: As directed by the City Engineer, Matich Corporation is directed to remove and replace the existing ADA ramp at the south east corner of Larch and Merrill. The new ADA ramp is to be constructed over the existing storm drain and was laid-out in the filed by the City Project Manager and field inspector.

CCO#2, item No. 16: Contract Change Order No. 2, Item 16: As directed by the City Engineer, Matich Corporation was compensated for standby time while the Water Department repaired an unmarked water line impeding the progress of Matich's planned activities.

CCO#2, item No. 17: Contract Change Order No. 2, Item 17: As directed by the City Engineer, Matich Corporation was compensated for standby time while the City investigated unsuitable subgrade on the South Side of Valley Boulevard east of Riverside Avenue. In addition, Matich was directed to remove and replace areas found to unsuitable to receive the planned asphalt cap by removing the existing asphalt, base, and subgrade to a depth of +-6". The removal areas were recompacted and the final asphalt paving was placed over the remediated areas.

CCO#2, item No. 18: Contract Change Order No. 2, Item 18: As directed by the City Engineer, Matich Corporation is directed to install 3 additional sign posts and perform additional striping as directed by the City on Rialto Avenue. The final location of the of the sign posts will be installed pursuant to the direction of the field engineer.

CCO#2, item No. 19: Contract Change Order No. 2, Item 19: As directed by the City Engineer, Matich Corporation is directed to an additional "homerun" for the loops in Merrill Avenue eastbound at Riverside Avenue to the existing controller.

CCO#2, item No. 20: Contract Change Order No. 2, Item 20: Balancing of final contract quantities to match the actual amounts used in the construction of the project.

CCO#2, item No. 21: Contract Change Order No. 2, Item 21: Balancing of final contract quantities to match the actual amounts used in the construction of the project for work related to Contract Change Order No. 2.

CHANGES IN COST:

CCO#2, Item 1: As directed by the City Engineer, Matich Corporation is directed to construct a City of Rialto Standard Plan SC-215 ADA ramp instead of the planned Caltrans Standard Plan ADA ramp A88A/A88B at the S/W/C for Sycamore and Rialto. The work was performed at time and materials pursuant to Section 3-3 of the Project Special Provisions. Compensation for said work shall be in accordance with Contractor's cost proposal dated 5-8-19 and is attached to this change order. The total lump sum cost associated with this item of work shall be \$488.35. The sum constitutes full compensation, including mark-ups, for the work described in this change order.

CCO#2, Item 2: As directed by the City Engineer, Matich Corporation is directed to utilize 4000 PSI PCC for the construction of the driveways, and adjacent curb/gutter, along Valley Boulevard East. Compensation for said work shall be in accordance with Contractor's cost proposal dated May 13, 2019, attached hereto. The total lump sum cost associated with this item of work shall be \$1,452.50. The aforementioned sum constitutes full compensation, including mark-ups, for the work described in this change order.

CCO#2, Item 3: As directed by the City Engineer, Matich Corporation is directed to make revisions to the original striping plans sheets 12 and 13 on Merrill Avenue. Compensation for said work shall be in accordance with Contractor's cost proposal dated June 10, 2019, attached hereto. The total lump sum cost associated with this item of work shall be \$2,047.00. The aforementioned sum constitutes full compensation, including mark-ups, for the work described in this change order.

CCO#2, Item 4: As directed by the City Engineer, Matich Corporation is to install a reflective street name sign in lieu of the originally designated ISNS sign to be installed at Merrill and Cedar. This change was in response to the Contractor's RFI No. 2. Compensation for said work shall be in accordance with Contractor's cost proposal dated 5-31-19, attached hereto. The total lump sum cost associated with this item of work shall be ~~(\$-~~1,970.00). The sum constitutes full compensation, including mark-ups, for the work described in this change order.

CCO#2, Item 5: As directed by the City Engineer, Matich Corporation is to relocate previously placed project information signs from their original location to new locations designed by the field engineer. Compensation for said work shall be in accordance with Contractor's cost proposal dated 5-31-19, labeled CCR 7.01, attached hereto. The total lump sum cost associated with this item of work shall be \$635.61. The sum constitutes full compensation, including mark-ups, for the work described in this change order.

CCO#2, Item 6: As directed by the City Engineer, Matich Corporation is directed to perform additional pot-holing for the unmarked/unknown storm drain in Merrill Avenue. Compensation for said work shall be in accordance with Contractor's cost proposal dated 8-5-19, labeled CCR 7.02, attached hereto. The total lump sum cost associated with this item of work shall be \$293.71. The sum constitutes full compensation, including mark-ups, for the work described in this change order.

CCO#2, Item 7: As directed by the City Engineer, Matich Corporation is directed to perform additional saw-cutting of a previously saw-cut ADA ramp. The ramp was saw-cut pursuant to the original design; however, the City requested a change to the ramp, which required additional saw-cutting to accommodate the redesign of the ramp. Compensation for said work shall be in accordance with Contractor's cost proposal dated 8-5-19, labeled CCR 7.03, attached hereto. The total lump sum cost associated with this item of work shall be

\$1,529.38. The sum constitutes full compensation, including mark-ups, for the work described in this change order.

CCO#2, Item 8: As directed by the City Engineer, Matich Corporation is directed to purchase and install 5 new 17" x 30" traffic signal pull boxes damaged prior to the construction of the project. Compensation for said work shall be in accordance with Contractor's cost proposal dated 8-5-19, labeled CCR 7.04, attached hereto. The total lump sum cost associated with this item of work shall be **\$650.11**. The sum constitutes full compensation, including mark-ups, for the work described in this change order.

CCO#2, Item 9: As directed by the City Engineer, Matich Corporation is directed to install a 3' wide ribbon gutter on Rialto Avenue behind an existing approach on Rialto Avenue. Compensation for said work shall be in accordance with Contractor's cost proposal dated 8-5-19, labeled CCR 7.05, attached hereto. The total lump sum cost associated with this item of work shall be **\$658.00**. The sum constitutes full compensation, including mark-ups, for the work described in this change order.

CCO#2, Item 10: As directed by the City Engineer, Matich Corporation is directed to remove existing concrete curb/gutter and sidewalk to accommodate redesign of the ADA ramp. The work was done after the removal of the existing PCC and required remobilization to perform the work. Compensation for said work shall be in accordance with Contractor's cost proposal dated 8-5-19, labeled CCR 7.06, attached hereto. The total lump sum cost associated with this item of work shall be **\$657.40**. The sum constitutes full compensation, including mark-ups, for the work described in this change order.

CCO#2, Item 11: As directed by the City Engineer, Matich Corporation is directed to remove existing concrete and asphalt pavement at Station 15+65 on Rialto Avenue to accommodate the redesign of an ADA complaint driveway. Compensation for said work shall be in accordance with Contractor's cost proposal dated 8-5-19, labeled CCR 7.07, attached hereto. The total lump sum cost associated with this item of work shall be **\$1,323.67**. The sum constitutes full compensation, including mark-ups, for the work described in this change order.

CCO#2, Item 12: As directed by the City Engineer, Matich Corporation is directed to repair a shallow and unmarked water line servicing Clutch Masters on Valley Boulevard. The line was installed directly underneath the existing concrete sidewalk and was damaged during the removal process. Compensation for said work shall be in accordance with Contractor's cost proposal dated 8-5-19, labeled CCR 7.08, attached hereto. The total lump sum cost associated with this item of work shall be **\$2,268.94**. The sum constitutes full compensation, including mark-ups, for the work described in this change order.

CCO#2, Item 13: As directed by the City Engineer, Matich Corporation is directed to saw-cut for an additional driveway on Valley at the P&S Truck Center. Compensation for said work shall be in accordance with Contractor's cost proposal dated 8-5-19, labeled CCR 7.09, attached hereto. The total lump sum cost associated with this item of work shall be **\$485.90**. The sum constitutes full compensation, including mark-ups, for the work described in this change order.

CCO#2, Item 14: As directed by the City Engineer, Matich Corporation is directed to remove portions of a previously constructed ADA ramp at Southwest corner of Linden and Foothill to accommodate the City's redesign of the originally constructed ramp. Compensation for said work shall be in accordance with Contractor's cost proposal dated 8-5-19, labeled CCR 7.10, attached hereto. The total lump sum cost associated with this item of work shall be **\$4,631.44**. The sum constitutes full compensation, including mark-ups, for the work described in this change order.

CCO#2, Item 15: As directed by the City Engineer, Matich Corporation is directed to remove and replace the existing concrete ramp at the south east corner of Larch and Merrill as directed by the City's Project Manager and the field inspector. The new ramp is to be constructed over an existing storm drain, and is considered a custom ramp, as the standard detail would allow for the installation of a standard ADA compliant ramp. Compensation for said work shall be in accordance with Contractor's cost proposal dated 8-5-19, labeled CCR 7.11, attached hereto. The total lump sum cost associated with this item of work shall be \$8,105.72. The sum constitutes full compensation, including mark-ups, for the work described in this change order.

CCO#2, Item 16: As directed by the City Engineer, Matich Corporation was compensated for crew standby time while Veolia identified and repaired an unmarked water line impeding the progress of the work. Compensation for said work shall be in accordance with Contractor's cost proposal dated 8-5-19, labeled CCR 7.12, attached hereto. The total lump sum cost associated with this item of work shall be \$2,386.13. The sum constitutes full compensation, including mark-ups, for the work described in this change order.

CCO#2, Item 17: As directed by the City Engineer, Matich Corporation was compensated for crew standby time while the City investigated the subgrade issues at the South Side of Valley Boulevard east of Riverside Avenue. In addition, Matich was directed to remove and replace areas found to unsuitable to receive the planned asphalt cap by removing the existing asphalt, base, and subgrade to a depth of +6". The removal areas were recompacted and the final asphalt paving was placed over the remediated areas. Compensation for said work shall be in accordance with Contractor's cost proposal dated 8-5-19, labeled CCR 7.13, attached hereto. The total lump sum cost associated with this item of work shall be \$16,547.56. The sum constitutes full compensation, including mark-ups, for the work described in this change order.

CCO#2, Item 18: As directed by the City Engineer, Matich Corporation is directed to install 3 additional sign posts and perform additional striping removal as directed by the City's Project Manager and project inspector. Compensation for said work shall be in accordance with Contractor's cost proposal dated 8-5-19, labeled CCR 7.13, attached hereto. The total lump sum cost associated with this item of work shall be \$745.82. The sum constitutes full compensation, including mark-ups, for the work described in this change order.

CCO#2, Item 19: As directed by the City Engineer, Matich Corporation is directed to install a "homerun" for the loops in Merrill Avenue eastbound at Riverside Avenue to the existing controller. Compensation for said work shall be in accordance with Contractor's cost proposal dated 8-5-19, labeled CCR 7.13, attached hereto. The total lump sum cost associated with this item of work shall be \$1,104.27. The sum constitutes full compensation, including mark-ups, for the work described in this change order.

CCO#2, Item 20: Increase/decrease to Bid Items at agreed unit Prices: See attached Exhibit "A" for final accounting of original contract Bid Items. Total increase = \$20,046.48

CCO#2, Item 21: Increase/decrease to Bid Items at agreed unit Prices for work associated with Contract Change Order No. 1: See attached Exhibit "B" for final accounting of original contract Bid Items. Total increase = \$22,688.02

Contract Change Order No. 2
August 15, 2019
Page 6

CHANGES TO CONTRACT TIME:

The City agrees to grant an additional 21 Working Days to the contract time. The additional working days provide time to complete the change order work, and accommodate a change in the schedule that allowed a portion of the work on Merrill Avenue to occur during the Curtis Elementary School summer recess.

SUMMARY OF COSTS:

Original Contract Amount:	\$3,637,964.93	Original Completion	80 Working Days
Previous Change Order:	(-\$50,000.80)	Days Added	21 Working Days
This Change Order:	\$86,776.01	Previous Days Added:	0 Working Days
Revised Contract Amount:	\$3,674,740.14	Revised Completion	101 Working Days

*** SIGNATURES ON NEXT PAGE ***

I have received a copy of this Change Order and the above AGREED PRICES are acceptable to Contractor

Match Corporation

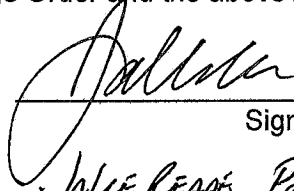

Signature
9/4/19

Date
Julie Read, Project Manager

Printed Name and Title

City of Rialto

Approved By:

Robert G. Eisenbeisz, P.E.,
Public Works Director/City Engineer

Date

Recommended By:

Jeffrey T. Schafer, P.E.
Associate Civil Engineer

Date

Distribution:

Original Conformed Copy:

Contractor (1)
City Clerk (1)
Resident Engineer (1)

Conformed - File Copy:

Engineering Pay File (1)
Accounting Technician (1)
Procurement (1)
Finance (1)

PROJECT: 2017-2018 Annual Street Overlay Project
 CITY PROJECT NUMBER 180804



Contractor:
 Match Corporation
 P.O. Box 10
 Highland, California 92346

EXHIBIT A
 Date: August 6, 2019

Item No.	Item Description	Units	Quantity	Unit Price	Original Contract Amount	Proposed Final Quantities		Amount Over/Under Construct		% Auth.
						Quantity	Amount	Quantity	Amount	
1	Mobilization	LS	1	\$34,535.24	\$34,535.24	1.00	\$34,535.24		\$0.00	0%
2	SWPPP	LS	1	\$1,637.89	\$1,637.89	1.00	\$1,637.89		\$0.00	0%
3	Construction Staking and Monument Perpetuation	LS	1	\$1,236.00	\$1,236.00	1.00	\$1,236.00		\$0.00	0%
4	Traffic Control	LS	1	\$15,461.18	\$15,461.18	1.00	\$15,461.18		\$0.00	0%
5	Remove Existing and Construct 4-Inch Thick POC Sidewalk	SF	610	\$12.04	\$7,344.40	1,046.50	\$12,599.86	436.50	\$5,255.46	72%
6	Remove Existing and Construct 8-Inch Curb and Gutter. Match Existing.	LF	270	\$41.77	\$11,277.90	345.00	\$14,410.65	75.00	\$3,132.75	28%
7	Remove Existing and Construct Spandrel and Cross Gutter, Width to Match Existing.	SF	55	\$29.51	\$1,623.05	155.00	\$4,574.05	100.00	\$2,951.00	182%
8	Remove Existing and Construct Access Ramp Per City of Railto Std. SC-215, Type 6, Case A, Includes Installation Of Pre-Cast Detectable Warning Surface, Curb and Gutter, Retaining Curbs and Replacement of Adjacent SW And AC Pavement From BCR To ECR, Complete	EA	4	\$4,015.13	\$16,060.52	4.00	\$16,060.52		\$0.00	0%
9	Remove Existing and Construct Access Ramp Per Caltrans Std. Plan RSP A88A And RSP A88B, Case Per Plan, Includes Installation Of Pre-Cast Detectable Warning Surface, Curb and Gutter, Retaining Curbs and Replacement of Adjacent SW And AC Pavement from BCR	EA	6	\$3,388.92	\$20,333.52	6.00	\$20,333.52		\$0.00	0%
10	Remove Existing and Construct Driveway Approach	SF	390	\$12.41	\$4,839.90	416.00	\$5,162.56	26.00	\$322.66	7%
11	Coldmill Existing AC Pavement Variable Depth (0.0' to 0.17')	SY	800	\$2.97	\$2,376.00	686.00	\$2,037.42	-114.00	-\$338.58	-14%
12	Roadway Excavation (0.42' to 0.85') - Unclassified Excavation	CY	850	\$34.36	\$29,206.00	963.00	\$33,088.68	113.00	\$3,882.68	13%
13	Asphalt Concrete (Base and Level)	TON	1,700	\$57.77	\$98,209.00	1,787.53	\$103,265.61	87.53	\$5,056.61	5%
14	Asphalt Rubber Hot Mix (ARHM) Surface Course	TON	625	\$93.92	\$58,700.00	663.91	\$62,354.43	38.91	\$3,654.43	6%
15	Adjust Water Valve Frame and Cover to Grade	EA	9	\$517.45	\$4,657.05	9.00	\$4,657.05		\$0.00	0%
16	Adjust Manhole Frame and Cover to Grade	EA	10	\$1,242.62	\$12,426.20	10.00	\$12,426.20		\$0.00	0%

17	Traffic Striping, Signage & Markings	LS	1	\$8,181.15	\$8,181.15	1.00	\$8,181.15	1.00	\$8,181.15	0%	\$0.00	0%
18	Traffic Detector Loops (Type E)	EA	6	\$257.50	\$1,545.00	6.00	\$1,545.00	6.00	\$1,545.00	0%	\$0.00	0%
TOTALS SCHEDULE A - Project Site 1 Linden Avenue					\$3,295,650.00		\$3,295,650.00		\$3,295,650.00		\$23,937.01	

ED SCHEDULE B - Project Site 2/ Merrill Avenue

1	Mobilization	LS	1	\$95,291.76	\$95,291.76	1.00	\$95,291.76	1.00	\$95,291.76	0%	\$0.00	0%
2	SVPPP	LS	1	\$30,157.49	\$30,157.49	1.00	\$30,157.49	1.00	\$30,157.49	0%	\$0.00	0%
3	Construction Staking and Monument Perpetuation	LS	1	\$8,284.15	\$8,284.15	1.00	\$8,284.15	1.00	\$8,284.15	0%	\$0.00	0%
4	Traffic Control	LS	1	\$67,164.45	\$67,164.45	1.00	\$67,164.45	1.00	\$67,164.45	0%	\$0.00	0%
5	Remove Existing and Construct 4-Inch Thick POC Sidewalk	SF	4,230	\$10.48	\$44,330.40	4,187.00	\$43,879.76	-43.00	-\$450.64	-1%	\$0.00	-1%
6	Remove Existing and Construct 8-Inch Curb and Gutter, Match Existing.	LF	340	\$41.86	\$14,232.40	328.00	\$13,730.08	-12.00	-\$502.32	-4%	\$0.00	-4%
7	Remove Existing and Construct Spandrel and Cross Gutter, Width to Match Existing.	SF	160	\$25.81	\$4,129.60	159.00	\$4,103.79	-1.00	-\$25.81	-1%	\$0.00	-1%
8	Install Surface Mounted Detectable Warning Surface	EA	4	\$1,413.61	\$5,654.44	4.00	\$5,654.44		\$0.00	0%	\$0.00	0%
9	Remove Existing and Construct Access Ramp Per City of Palo Alto Std. SC-215, Type 6, Case A, Includes Installation Of Pre-Cast Detectable Warning Surface, Curb and Gutter, Retaining Curbs and Replacement of Adjacent SW And AC Pavement From BCR To ECR, Complete	EA	5	\$4,132.26	\$20,661.30	6.00	\$24,793.56	1.00	\$4,132.26	20%	\$0.00	20%
10	Remove Existing and Construct Access Ramp Per Caltrans Std. Plan RSP A88A And RSP A88B, Case Per Plan, Includes Installation Of Pre-Cast Detectable Warning Surface, Curb and Gutter, Retaining Curbs and Replacement of Adjacent SW And AC Pavement from BCR	EA	16	\$3,306.59	\$52,937.44	14.00	\$46,320.26	-2.00	-\$6,617.18	-13%	\$0.00	-13%
11	Remove Tree and Roots	EA	6	\$2,045.29	\$12,271.74	6.00	\$12,271.74		\$0.00	0%	\$0.00	0%
12	Retrofit Existing Catch Basin Top Slab and Face Plate	LS	1	\$6,327.50	\$6,327.50	1.00	\$6,327.50		\$0.00	0%	\$0.00	0%
13	Coldmill Existing AC Pavement Variable Depth (0.0' to 0.17')	SY	12,810	\$1.13	\$14,475.30	12,739.00	\$14,395.07	-71.00	-\$80.23	-1%	\$0.00	-1%
14	Roadway Excavation (.42' to 0.85') - Unclassified Excavation - Delete per CCO No. 1	CY	8,700	\$22.53	\$196,011.00	8,700.00	\$196,011.00		\$0.00	0%	\$0.00	0%
15	Asphalt Concrete (Base and Level)	TON	8,435	\$59.93	\$505,509.55	8,314.19	\$498,269.41	-120.81	-\$7,240.14	-1%	\$0.00	-1%
16	Aggregate Base - Delete per CCO No. 1	CY	4,420	\$35.25	\$155,805.00	4,420.00	\$155,805.00		\$0.00	0%	\$0.00	0%

17	Shoulder Backing	LF	1,220	\$4.08	\$4,977.60	730.00	\$2,978.40	-490.00	-\$1,999.20	-40%
18	Asphalt Rubber Hot Mix (ARHM) Surface Course	TON	7,510	\$77.57	\$582,550.70	7,847.20	\$608,707.30	337.20	\$26,156.60	4%
19	Adjust Water Valve Frame and Cover to Grade	EA	109	\$518.24	\$56,488.16	121.00	\$62,707.04	12.00	\$6,218.88	11%
20	Adjust Manhole Frame and Cover to Grade	EA	34	\$1,243.79	\$42,288.86	34.00	\$42,288.86		\$0.00	0%
21	Traffic Striping, Signage & Markings	LS	1	\$60,527.28	\$60,527.28	1.00	\$60,527.28		\$0.00	0%
22	Traffic Detector Loops (Type E)	EA	65	\$259.20	\$16,848.00	56.00	\$14,515.20	-9.00	-\$2,332.80	-14%
23	Install ISSNS on Signal Mast Arm	EA	1	\$12,426.23	\$12,426.23	1.00	\$12,426.23		\$0.00	0%
TOTAL BID SCHEDULE B - Project Site 2 Merill Avenue					\$2,009,350.35		\$2,026,509.77		\$17,159.42	

BD SCHEDULE C - Project Site 3/ Ralco Avenue

1	Mobilization	LS	1	\$29,575.61	\$29,575.61	1.00	\$29,575.61		\$0.00	0%
2	SWPPP	LS	1	\$2,616.39	\$2,616.39	1.00	\$2,616.39		\$0.00	0%
3	Construction Staking and Monument Perpetuation	LS	1	\$824.00	\$824.00	1.00	\$824.00		\$0.00	0%
4	Traffic Control	LS	1	\$12,863.03	\$12,863.03	1.00	\$12,863.03		\$0.00	0%
5	Remove Existing and Construct 4-inch Thick POC Sidewalk	SF	2,150	\$7.68	\$16,512.00	2,347.50	\$18,028.80	197.50	\$1,516.80	9%
6	Remove Existing and Construct 8-inch Curb and Gutter. Match Existing.	LF	20	\$79.09	\$1,581.80	56.00	\$4,429.04	36.00	\$2,847.24	180%
7	Remove Existing and Construct Spandrel and Cross Gutter. Width to Match Existing.	LF	85	\$39.06	\$3,320.10	180.00	\$6,249.60	75.00	\$2,929.50	88%
8	Remove Existing and Construct Curb Only (6" or 8")	LF	75	\$22.67	\$1,700.25	80.00	\$1,813.60	5.00	\$113.35	7%
9	Remove Existing and Construct Spandrel and Cross Gutter. Width to Match Existing.	SF	145	\$28.48	\$4,129.60	149.00	\$4,243.52	4.00	\$113.92	3%
10	Install Surface Mounted Detectable Warning Surface	EA	7	\$1,438.33	\$10,068.31	7.00	\$10,068.31		\$0.00	0%
11	Remove Existing and Construct Access Ramp Per Caltrans Std. Plan RSP A88A And RSP A88B, Case Per Plan, Includes Installation Of Pre-Cast Detectable Warning Surface, Curb and Gutter, Retaining Curbs and Replacement of Adjacent SW And AC Pavement from BCR	EA	3	\$3,585.35	\$10,756.05	3.00	\$10,756.05		\$0.00	0%
12	Remove Existing and Construct Driveway Approach	SF	1,265	\$12.44	\$15,736.60	836.00	\$10,399.84	-429.00	-\$5,336.76	-34%
13	Remove and Reinstall 22" x 8" (14 GA) Arch CMP	LF	150	\$326.10	\$48,915.00		\$0.00	-150.00	-\$48,915.00	-100%
14	Coldmill Existing AC Pavement Variable Depth (0.0' to 0.17')	SY	1,230	\$2.76	\$3,394.80	1,704.00	\$4,703.04	474.00	\$1,308.24	39%

15	Coldmill Existing AC Pavement Uniform Depth (0.10' to 0.20')	SY	5,180	\$1.54	\$7,977.20	5,273.00	\$8,120.42	93.00	\$143.22	2%
16	Roadway Excavation (0.42' to 0.85') - Unclassified Excavation	CY	35	\$146.57	\$5,129.95	32.00	\$4,690.24	-3.00	-\$439.71	-9%
17	Asphalt Concrete (Base and Level)	TON	640	\$62.46	\$39,974.40	627.71	\$39,206.77	-12.29	-\$767.63	-2%
18	Shoulder Backing	LF	550	\$4.54	\$2,497.00	525.00	\$2,383.50	-25.00	-\$113.50	-5%
19	Asphalt Rubber Hot Mix (ARHM) Surface Course	TON	710	\$85.80	\$60,918.00	720.47	\$61,816.33	10.47	\$898.33	1%
20	Adjust Water Valve Frame and Cover to Grade	EA	10	\$517.21	\$5,172.10	12.00	\$6,206.52	2.00	\$1,034.42	20%
21	Adjust Manhole Frame and Cover to Grade	EA	4	\$1,241.52	\$4,966.08	5.00	\$6,207.60	1.00	\$1,241.52	25%
22	Traffic Striping, Signage & Markings	LS	1	\$7,254.15	\$7,254.15	1.00	\$7,254.15		\$0.00	0%
23	Traffic Detector Loops (Type E)	EA	8	\$280.27	\$2,082.16	8.00	\$2,082.16		\$0.00	0%
FOR BIDDING SCHEDULED PROJECT SITE 3 Baro Avenue \$297,964.53 \$2,575,385.52 \$45,476.06										

BID SCHEDULE D - Project Site 4/ Valley Boulevard (BCR ECR West of Cactus to 640' E/O Libac Ave)

1	Mobilization	LS	1	\$65,814.07	\$65,814.07	1.00	\$65,814.07		\$0.00	0%
2	SWPPP	LS	1	\$4,767.96	\$4,767.96	1.00	\$4,767.96		\$0.00	0%
3	Construction Staking and Monument Perpetuation	LS	1	\$1,236.00	\$1,236.00	1.00	\$1,236.00		\$0.00	0%
4	Traffic Control	LS	1	\$18,103.40	\$18,103.40	1.00	\$18,103.40		\$0.00	0%
5	Remove Existing and Construct 4-Inch Thick POC Sidewalk	SF	1,290	\$10.22	\$13,183.80	537.00	\$5,488.14	-753.00	-\$7,695.66	-58%
6	Remove Existing and Construct 8-Inch Curb and Gutter; Match Existing.	LF	135	\$41.45	\$5,595.75	143.70	\$5,956.37	8.70	\$360.62	6%
7	Coldmill Existing AC Pavement Variable Depth (0.0' to 0.17')	SY	1,880	\$2.73	\$5,132.40	2,439.00	\$6,658.47	559.00	\$1,526.07	30%
8	Coldmill Existing AC Pavement Uniform Depth (0.10' to 0.20')	SY	5,450	\$0.84	\$4,578.00	6,466.00	\$5,431.44	1,016.00	\$853.44	19%
9	Roadway Excavation (0.42' to 0.85') - Unclassified Excavation - Delete per CCO No. 1	CY	1,840	\$37.23	\$68,503.20	1,840.00	\$68,503.20		\$0.00	0%
10	Asphalt Concrete (Base and Level)	TON	2,050	\$69.72	\$142,926.00	2,050.00	\$142,926.00		\$0.00	0%
11	Aggregate Base - Delete per CCO No. 1	CY	900	\$70.53	\$63,477.00	900.00	\$63,477.00		\$0.00	0%
12	Pavement Fabric	SY	1,815	\$2.71	\$4,918.65	1,700.00	\$4,607.00	-115.00	-\$311.65	-6%
13	Shoulder Backing	LF	290	\$3.42	\$991.80	308.00	\$1,053.36	18.00	\$61.56	6%
14	Asphalt Rubber Hot Mix (ARHM) Surface Course	TON	1,940	\$78.25	\$151,805.00	2,111.26	\$165,206.10	171.26	\$13,401.10	9%

15	Adjust Water Valve Frame and Cover to Grade	EA	31	\$517.85	\$16,053.35	32.00	\$16,571.20	1.00	\$517.85	3%
16	Adjust Manhole Frame and Cover to Grade	EA	7	\$1,242.31	\$8,696.17	7.00	\$8,696.17		\$0.00	0%
17	Traffic Striping, Signage & Markings	LS	1	\$17,105.37	\$17,105.37	1.00	\$17,105.37		\$0.00	0%
18	Traffic Detector Loops (Type E)	EA	12	\$259.34	\$3,112.08	2.00	\$518.68	-10.00	-\$2,593.40	-83%
TOTAL BID SCHEDULE E - Project Site 4 Valley Boulevard (Borek Way) to Centis to East City Limit \$517,850.00 \$16,053.35 32.00 \$16,571.20 1.00 \$517.85 3%										

BID SCHEDULE E - Project Site 5/ Valley Boulevard (Riverside Ave. to East City Limit)

1	Mobilization	LS	1	\$45,337.04	\$45,337.04	1.00	\$45,337.04		\$0.00	0%
2	SWPPP	LS	1	\$3,531.96	\$3,531.96	1.00	\$3,531.96		\$0.00	0%
3	Construction Staking and Monument Perpetuation	LS	1	\$412.00	\$412.00	1.00	\$412.00		\$0.00	0%
4	Traffic Control	LS	1	\$18,103.40	\$18,103.40	1.00	\$18,103.40		\$0.00	0%
5	Remove Existing and Construct 8-Inch Curb and Gutter. Match Existing.	LF	315	\$37.46	\$11,799.90	630.50	\$23,618.53	315.50	\$11,818.63	100%
6	Remove Existing and Construct Driveway Approach	SF	2,990	\$11.04	\$33,009.60	3,307.50	\$36,514.80	317.50	\$3,505.20	11%
7	Coldmill Existing AC Pavement Variable Depth (0.0' to 0.17')	SY	685	\$3.46	\$2,370.10	757.00	\$2,619.22	72.00	\$249.12	11%
8	Coldmill Existing AC Pavement Uniform Depth (0.10' to 0.20')	SY	4,175	\$1.22	\$5,093.50	3,279.00	\$4,000.38	-896.00	-\$1,093.12	-21%
9	Roadway Excavation (0.42' to 0.85') - Unclassified Excavation - Delete per CCO No. 1	CY	1,150	\$30.12	\$34,638.00	1,150.00	\$34,638.00		\$0.00	0%
10	Asphalt Concrete (Base and Level)	TON	1,410	\$66.75	\$94,117.50	1,393.61	\$93,023.47	-16.39	-\$1,094.03	-1%
11	Aggregate Base - Delete per CCO No. 1	CY	570	\$83.14	\$47,389.80	570.00	\$47,389.80		\$0.00	0%
12	Pavement Fabric	SY	1,030	\$4.10	\$4,223.00	900.00	\$3,690.00	-130.00	-\$533.00	-13%
13	Asphalt Rubber Hot Mix (ARHM) Surface Course	TON	980	\$84.91	\$83,211.80	1,019.14	\$86,535.18	39.14	\$3,323.38	4%
14	Adjust Water Valve Frame and Cover to Grade	EA	15	\$517.94	\$7,769.10	15.00	\$7,769.10		\$0.00	0%
15	Adjust Manhole Frame and Cover to Grade	EA	5	\$1,244.83	\$6,224.15	5.00	\$6,224.15		\$0.00	0%
16	Traffic Striping, Signage & Markings	LS	1	\$7,254.15	\$7,254.15	1.00	\$7,254.15		\$0.00	0%
17	Traffic Detector Loops (Type E)	EA	2	\$257.50	\$515.00	2.00	\$515.00		\$0.00	0%
TOTAL BID SCHEDULE E - Project Site 5 Valley Boulevard (Riverside Ave. to East City Limit) \$421,176.16 \$405,000.00 421.00 \$421,176.16										

GRAND TOTAL BID SCHEDULE A + BID SCHEDULE B + BID SCHEDULE C + BID SCHEDULE D + BID SCHEDULE E \$9,558,011.44 \$9,558,011.44										
---	--	--	--	--	--	--	--	--	--	--

PROJECT: 2017-2018 Annual Street Overlay Project
 CITY PROJECT NUMBER: 180804



Contractor: Match Corporation
 Address: P.O. Box 10
 Highland, California 92346
 City, State, Zip:

EXHIBIT B
 Date: August 6, 2019

Item No.	Item Description	Units	Quantity	Unit Price	Original Contract Amount	Proposed Final Quantities		Amount Over/Under Construct	Amount	% Auth.
						Quantity	Amount			
CONTRACT CHANGE ORDERS:										
	Contract Change Order No. 1									
	Bid Schedule B									
Item No. 1	Delete Bid Item No. 14, Schedule B, Roadway Excavation	CY	(8,700)	\$22.53	(\$196,011.00)	-8,700.00			-\$196,011.00	0%
Item No. 2	Delete Bid Item No. 16, Schedule B, Aggregate Base	CY	(4,420)	\$35.25	(\$155,805.00)	-4,420.00			-\$155,805.00	0%
Item No. 3	Pulverize and mix existing AC pavement and subgrade to depth of 0.67', followed by roadway excavation of 0.33' of the pulverized material.	CY	4,200	\$40.94	\$171,948.00	4,633.00	433.00		\$189,675.02	10%
Item No. 4	Add 2% cement to remaining pulverized material to create .33' cement treated pulverized base.	SF	337,000	\$0.55	\$185,350.00	346,020.00	9,020.00		\$4,961.00	3%
	Bid Schedule D									
Item No. 5	Delete Bid Item No. 9, Schedule D, Roadway Excavation	CY	(1,840)	\$37.23	(\$68,503.20)	-1,840.00			-\$68,503.20	0%
Item No. 6	Delete Bid Item No. 11, Schedule D, Aggregate Base	CY	(900)	\$70.53	(\$63,477.00)	-900.00			-\$63,477.00	0%
Item No. 7	Roadway Excavation to a depth of 0.50'	CY	1,260	\$52.73	\$66,439.80	1,260.00			\$66,439.80	0%
Item No. 8	Construct additional 0.17' AC leveling course and base paving	TN	673	\$51.55	\$34,693.15	673.00			\$34,693.15	0%
	Bid Schedule E									
Item No. 9	Delete Bid Item No. 9, Schedule E, Roadway Excavation	CY	(1,150)	\$30.12	(\$34,638.00)	-1,150.00			-\$34,638.00	0%
Item No. 10	Delete Bid Item No. 11, Schedule E, Aggregate Base	CY	(570)	\$83.14	(\$47,389.80)	-570.00			-\$47,389.80	0%
Item No. 11	Roadway Excavation to a depth of 0.50'	CY	800	\$54.02	\$43,216.00	800.00			\$43,216.00	0%
Item No. 12	Construct additional 0.17' AC leveling course and base paving	TN	275	\$51.55	\$14,176.25	275.00			\$14,176.25	0%
	Total Change Order No. 1									\$22,688.02



City PCO No. 8

May 8, 2019

Willdan Engineering
13191 Crossroads Parkway North, Suite 405
Industry, CA 91746

Attn: Barry Knutson, Construction Manager

Re: 2017/18 Annual Street Overlay Project, City Project Number. 180804
Change Order Request – Access Ramp at South West Corner of Sycamore and Rialto

Dear Barry:

Matich Corporation respectfully submits this correspondence as a change order request to construct a City of Rialto Standard SC-215 access ramp instead of a Caltrans Standard A88A / A88B at the south west corner of Sycamore and Rialto. The conditions in the field required the change in ramp construction at this location. The difference in price for the two types of ramps is prepared by averaging bid items A-8 and B-9 for the Rialto SC-215 Standard to reach a unit price of \$4,073.70, then subtracting bid item C-11 (\$3,585.35) for the Caltrans Standard A88A / A88B from that average price. The result is an additional \$488.35. Please prepare a contract change order in the amount of \$488.35 for the change in this ramp.

Please do not hesitate to contact me with questions.

Respectfully,

Matich Corporation

A handwritten signature in black ink, appearing to read 'J. Reade', is written over a white background.

by Jake Reade

Copy: File
Bcc:
Attachments:



City PCO No. 11

May 13, 2019

Willdan Engineering
13191 Crossroads Parkway North, Suite 405
Industry, CA 91746

Attn: Barry Knutson, Construction Manager

Re: 2017/18 Annual Street Overlay Project, City Project Number. 180804
Change Order Request – 4000 PSI PCC for Valley Driveways

Dear Barry:

Matich Corporation respectfully submits this correspondence as a change order request to provide a 4,000 PSI concrete mix for the concrete driveways on Valley Boulevard East. Between April 18 and April 30, 2019, a total of 145.25 cubic yards of the 4,000 PSI mix was used for the driveways and adjacent curb and gutter. It was originally estimated that the total cubic yards would be around 90 CY, however due to the fact the adjacent curb and gutter was to be poured at the same time the 4,000 PSI mix was used for both. The time restraints and short load fees required to switch back and forth between concrete mixes would have been to time restrictive and costly. Please prepare a contract change order in the amount of \$1,452.50 (145.25 CY at \$10.00 per CY) for the use of the 4,000 PSI mix.

Please do not hesitate to contact me with questions.

Respectfully,

Matich Corporation

A handwritten signature in black ink, appearing to read 'Jake Reade', is written over a white background.

by Jake Reade

Copy: File

Bcc:

Attachments:

660-CW-4000 PCC for Valley Blvd Driveways

Date	Cubic Yards
4/18/2019	20.00
4/19/2019	27.00
4/22/2019	17.50
4/23/2019	15.50
4/24/2019	13.50
4/25/2019	17.00
4/26/2019	24.75
4/30/2019	10.00
Total	145.25



RANCHO READY MIX PRODUCTS, L.P.

28251 LAKE STREET • LAKE ELSINORE, CA 92530
TEL: (951) 245-2460

RECEIVED

APR 29 2019

MATICH CORP.
Page: 1

MATICH CORPORATION
P.O. BOX 10
HIGHLAND, CA 92346

Cust/Job #:
18049-MERRILL & RIVERSIDE
000089 18049-VALLEY & RIVERSIDE
RIALTO

CUSTOMER	INVOICE	DATE	TERMS		
13068	107789	04/18/2019	10TH OF FOLLOWING MONTH		
DESCRIPTION	QUANTITY	UM	PRICE	AMOUNT	
Ticket Number 002-129154	04/18/2019				
660-CW-4000 GREENBOOK	10.00	CY	80.00	800.00	
FUEL SURCHARGE	1.00	LD	20.00	20.00	
PREVAILING WAGE CHARGE	1.00	LD	220.00	220.00	
ENVIRONMENTAL FEE	1.00	LD	40.00	40.00	
Ticket Number 002-129162	04/18/2019				
660-CW-4000 GREENBOOK	10.00	CY	80.00	800.00	
FUEL SURCHARGE	1.00	LD	20.00	20.00	
PREVAILING WAGE CHARGE	1.00	LD	220.00	220.00	
ENVIRONMENTAL FEE	1.00	LD	40.00	40.00	
TOTAL YARDS:	20.00				
JOB TAX				167.40	
JOB TOTAL				2327.40	

TAXABLE AMOUNT	2,160.00
EXEMPT AMOUNT	0.00
SALES TAX	167.40
INVOICE TOTAL	2,327.40

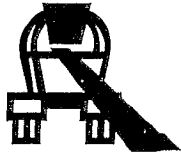

RANCHO READY MIX PRODUCTS, L.P.

28251 LAKE STREET • LAKE ELSINORE, CA 92530
TEL: (951) 245-2460

RECEIVED

APR 29 2019

MATICH CORP.

Page: 1

MATICH CORPORATION
P.O. BOX 10
HIGHLAND, CA 92346

Cust/Job #:
18049-MERRILL & RIVERSIDE
000089 18049-VALLEY E/O RIVERSIDE
RIALTO

CUSTOMER	INVOICE	DATE	TERMS
13068	107832	04/19/2019	10TH OF FOLLOWING MONTH

DESCRIPTION	QUANTITY	UM	PRICE	AMOUNT
Ticket Number 002-129221				
660-CW-4000 GREENBOOK	10.00	CY	80.00	800.00
FUEL SURCHARGE	1.00	LD	20.00	20.00
PREVAILING WAGE CHARGE	1.00	LD	220.00	220.00
ENVIRONMENTAL FEE	1.00	LD	40.00	40.00
Ticket Number 002-129234				
660-CW-4000 GREENBOOK	10.00	CY	80.00	800.00
FUEL SURCHARGE	1.00	LD	20.00	20.00
PREVAILING WAGE CHARGE	1.00	LD	220.00	220.00
ENVIRONMENTAL FEE	1.00	LD	40.00	40.00
Ticket Number 002-129248				
660-CW-4000 GREENBOOK	7.00	CY	80.00	560.00
FUEL SURCHARGE	1.00	LD	20.00	20.00
PREVAILING WAGE CHARGE	1.00	LD	220.00	220.00
ENVIRONMENTAL FEE	1.00	LD	40.00	40.00

TOTAL YARDS: 27.00

JOB TAX	232.50
JOB TOTAL	3232.50

TAXABLE AMOUNT	3,000.00
EXEMPT AMOUNT	0.00
SALES TAX	232.50
INVOICE TOTAL	3,232.50

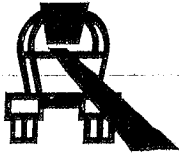

RANCHO READY MIX PRODUCTS, L.P.

RECEIVED

MAY 01 2019

MATCH CORP.

28251 LAKE STREET • LAKE ELSINORE, CA 92530
TEL: (951) 245-2460

Page: 1

MATCH CORPORATION
P.O. BOX 10
HIGHLAND, CA 92346

Cust/Job #:
18049-MERRILL & RIVERSIDE
000089 18049-VALLEY E/O RIVERSIDE
RIALTO

CUSTOMER	INVOICE	DATE	TERMS
13068	107889	04/22/2019	10TH OF FOLLOWING MONTH

DESCRIPTION	QUANTITY	UM	PRICE	AMOUNT
Ticket Number 002-129324				
	04/22/2019			
660-CW-4000 GREENBOOK	10.00	CY	80.00	800.00
FUEL SURCHARGE	1.00	LD	20.00	20.00
PREVAILING WAGE CHARGE	1.00	LD	220.00	220.00
ENVIRONMENTAL FEE	1.00	LD	40.00	40.00
Ticket Number 002-129334				
	04/22/2019			
660-CW-4000 GREENBOOK	7.50	CY	80.00	600.00
SHORT LOAD	1.00	LD	30.00	30.00
FUEL SURCHARGE	1.00	LD	20.00	20.00
PREVAILING WAGE CHARGE	1.00	LD	220.00	220.00
ENVIRONMENTAL FEE	1.00	LD	40.00	40.00

TOTAL YARDS: 17.50

JOB TAX	154.23
JOB TOTAL	2144.23

TAXABLE AMOUNT	1,990.00
EXEMPT AMOUNT	0.00
SALES TAX	154.23
INVOICE TOTAL	2,144.23

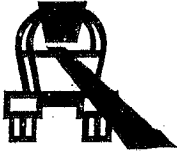

RANCHO READY MIX PRODUCTS, L.P.

RECEIVED

MAY 06 2019

28251 LAKE STREET • LAKE ELSINORE, CA 92530
TEL: (951) 245-2460

MATICH CORP.

Page: 1

MATICH CORPORATION
P.O. BOX 10
HIGHLAND, CA 92346

Cust/Job #:
18049-MERRILL & RIVERSIDE
000089 18049-VALLEY & SYCAMORE
RIALTO

CUSTOMER	INVOICE	DATE	TERMS		
13068	107928	04/23/2019	10TH OF FOLLOWING MONTH		
DESCRIPTION	QUANTITY	UM	PRICE	AMOUNT	
Ticket Number 002-129386		04/23/2019			
660-CW-4000 GREENBOOK	10.00	CY	80.00	800.00	
FUEL SURCHARGE	1.00	LD	20.00	20.00	
PREVAILING WAGE CHARGE	1.00	LD	220.00	220.00	
ENVIRONMENTAL FEE	1.00	LD	40.00	40.00	
Ticket Number 002-129396		04/23/2019			
660-CW-4000 GREENBOOK	5.50	CY	80.00	440.00	
SHORT LOAD	1.00	LD	50.00	50.00	
FUEL SURCHARGE	1.00	LD	20.00	20.00	
PREVAILING WAGE CHARGE	1.00	LD	220.00	220.00	
ENVIRONMENTAL FEE	1.00	LD	40.00	40.00	
TOTAL YARDS:	15.50				
JOB TAX				143.38	
JOB TOTAL				1993.38	

TAXABLE AMOUNT	1,850.00
EXEMPT AMOUNT	0.00
SALES TAX	143.38
INVOICE TOTAL	1,993.38

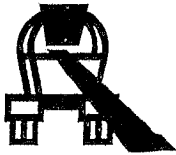

RANCHO READY MIX PRODUCTS, L.P.

RECEIVED

MAY 06 2019

28251 LAKE STREET • LAKE ELSINORE, CA 92530
TEL: (951) 245-2460

MATCH CORP.
Page: 1

MATCH CORPORATION
P.O. BOX 10
HIGHLAND, CA 92346

Cust/Job #:
18049-MERRILL & RIVERSIDE
000089 18049-VALLEY E/O LILAC
RIALTO

CUSTOMER	INVOICE	DATE	TERMS
13068	107961	04/24/2019	10TH OF FOLLOWING MONTH

DESCRIPTION	QUANTITY	UM	PRICE	AMOUNT
Ticket Number 002-129442				
	04/24/2019			
660-CW-4000 GREENBOOK	10.00	CY	80.00	800.00
FUEL SURCHARGE	1.00	LD	20.00	20.00
PREVAILING WAGE CHARGE	1.00	LD	220.00	220.00
ENVIRONMENTAL FEE	1.00	LD	40.00	40.00
Ticket Number 002-129453				
	04/24/2019			
660-CW-4000 GREENBOOK	3.50	CY	80.00	280.00
SHORT LOAD	1.00	LD	70.00	70.00
FUEL SURCHARGE	1.00	LD	20.00	20.00
PREVAILING WAGE CHARGE	1.00	LD	220.00	220.00
ENVIRONMENTAL FEE	1.00	LD	40.00	40.00

TOTAL YARDS: 13.50

JOB TAX	132.53
JOB TOTAL	1842.53

TAXABLE AMOUNT	1,710.00
EXEMPT AMOUNT	0.00
SALES TAX	132.53
INVOICE TOTAL	1,842.53



RANCHO READY MIX PRODUCTS, L.P.

RECEIVED

MAY 06 2019

28251 LAKE STREET • LAKE ELSINORE, CA 92530
TEL: (951) 245-2460

MATICH CORP.

Page: 1

MATICH CORPORATION
P.O. BOX 10
HIGHLAND, CA 92346

Cust/Job #:
18049-MERRILL & RIVERSIDE
000089 VALLEY E/O RIVERSIDE
RIALTO

CUSTOMER	INVOICE	DATE	TERMS		
13068	107988	04/25/2019	10TH OF FOLLOWING MONTH		
DESCRIPTION	QUANTITY	UM	PRICE	AMOUNT	
Ticket Number 002-129494					
	04/25/2019				
660-CW-4000 GREENBOOK	10.00	CY	80.00	800.00	
FUEL SURCHARGE	1.00	LD	20.00	20.00	
PREVAILING WAGE CHARGE	1.00	LD	220.00	220.00	
ENVIRONMENTAL FEE	1.00	LD	40.00	40.00	
Ticket Number 002-129499					
	04/25/2019				
660-CW-4000 GREENBOOK	7.00	CY	80.00	560.00	
SHORT LOAD	1.00	LD	30.00	30.00	
FUEL SURCHARGE	1.00	LD	20.00	20.00	
PREVAILING WAGE CHARGE	1.00	LD	220.00	220.00	
ENVIRONMENTAL FEE	1.00	LD	40.00	40.00	
TOTAL YARDS:	17.00				
JOB TAX				151.13	
JOB TOTAL				2101.13	

TAXABLE AMOUNT	1,950.00
EXEMPT AMOUNT	0.00
SALES TAX	151.13
INVOICE TOTAL	2,101.13



RANCHO READY MIX PRODUCTS, L.P.

RECEIVED

MAY 06 2019

MATCH CORP.

28251 LAKE STREET • LAKE ELSINORE, CA 92530

TEL: (951) 245-2460

Page: 1

MATCH CORPORATION
P.O. BOX 10
HIGHLAND, CA 92346

Cust/Job #:
18049-MERRILL & RIVERSIDE
000089 18049-VALLEY E/O RIVERSIDE
RIALTO

CUSTOMER	INVOICE	DATE	TERMS		
13068	108018	04/26/2019	10TH OF FOLLOWING MONTH		
DESCRIPTION	QUANTITY	UM	PRICE	AMOUNT	
Ticket Number 002-129565	04/26/2019				
660-CW-4000 GREENBOOK	10.00	CY	80.00	800.00	
FUEL SURCHARGE	1.00	LD	20.00	20.00	
PREVAILING WAGE CHARGE	1.00	LD	220.00	220.00	
ENVIRONMENTAL FEE	1.00	LD	40.00	40.00	
Ticket Number 002-129571	04/26/2019				
660-CW-4000 GREENBOOK	10.00	CY	80.00	800.00	
FUEL SURCHARGE	1.00	LD	20.00	20.00	
PREVAILING WAGE CHARGE	1.00	LD	220.00	220.00	
ENVIRONMENTAL FEE	1.00	LD	40.00	40.00	
Ticket Number 002-129579	04/26/2019				
660-CW-4000 GREENBOOK	4.75	CY	80.00	380.00	
FUEL SURCHARGE	1.00	LD	20.00	20.00	
PREVAILING WAGE CHARGE	1.00	LD	220.00	220.00	
ENVIRONMENTAL FEE	1.00	LD	40.00	40.00	
TOTAL YARDS:	24.75				
JOB TAX				218.55	
JOB TOTAL				3038.55	

TAXABLE AMOUNT	2,820.00
EXEMPT AMOUNT	0.00
SALES TAX	218.55
INVOICE TOTAL	3,038.55

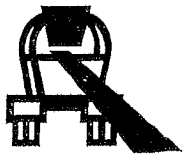

RANCHO READY MIX PRODUCTS, L.P.

RECEIVED

MAY 06 2019

28251 LAKE STREET • LAKE ELSINORE, CA 92530
TEL: (951) 245-2460

MATCH CORP.

Page: 1

MATCH CORPORATION
P.O. BOX 10
HIGHLAND, CA 92346

Cust/Job #:
18049-MERRILL & RIVERSIDE
000089 18049-VALLEY E/O RIVERSIDE
RIALTO

CUSTOMER	INVOICE	DATE	TERMS		
13068	108095	04/30/2019	10TH OF FOLLOWING MONTH		
DESCRIPTION	QUANTITY	UM	PRICE	AMOUNT	
Ticket Number 002-129689	04/30/2019				
660-CW-4000 GREENBOOK	10.00	CY	80.00	800.00	
FUEL SURCHARGE	1.00	LD	20.00	20.00	
PREVAILING WAGE CHARGE	1.00	LD	220.00	220.00	
ENVIRONMENTAL FEE	1.00	LD	40.00	40.00	
TOTAL YARDS:	10.00				
					JOB TAX 83.70
					JOB TOTAL 1163.70

TAXABLE AMOUNT	1,080.00
EXEMPT AMOUNT	0.00
SALES TAX	83.70
INVOICE TOTAL	1,163.70



June 10, 2019

Willdan Engineering
13191 Crossroads Parkway North, Suite 405
Industry, CA 91746

Attn: Barry Knutson, Construction Manager

Re: 2017/18 Annual Street Overlay Project, City Project Number. 180804
Change Order Request – Striping Changes on Merrill Avenue

Dear Barry:

Matich Corporation respectfully submits this correspondence as a change order request for revisions to striping plan sheets 12 and 13 on Merrill Avenue. Please prepare a change order in the amount of \$2,047.00 for this change if you wish to proceed with this work.

Please do not hesitate to contact me with questions.

Respectfully,

Matich Corporation

A handwritten signature in black ink, appearing to read 'Jake Reade', is written over the printed name.

by Jake Reade

Copy: File

Bcc:

Attachments: Cal Stripe Quote



CAL STRIPE INC.

2040 E. Steel Road
Colton, CA. 92324
Phone: (909) 884-7170
Fax: (909) 884-7106
Cell: (909) 206-7206
General Engineering Class A
Ca. Lic.# 685387
Signatory Laborers Union Local No.1184
DIR Registration #: 1000001100
ESTIMATOR: Adam Lippa

EXTRA WORK QUOTATION NO. 1 – Merrill Ave Changes

June 7, 2019

CAL STRIPE JOB No: 19006
PROJECT DESCRIPTION: 2017-2018 Annual Overlay
CONTRACT / PROJECT No: 19-005
PRIME CONTRACTOR NAME: Match
PRIME CONTRACTORS JOB NUMBER: 18-049

1. Cal Stripe Inc.'s subcontract proposal is good for 30 days only.
2. If this proposal is accepted, it is to be incorporated as an exhibit to the Contract or purchase order.
3. A signed purchase order, or subcontract is required prior to any work associated with this proposal.
4. Contractor to provide monthly progress payments for all completed work in accordance with the bid pricing schedule. Monthly progress payments must be received in full by Cal Stripe no later than 10 calendar days after the Contractor receives payment from Owner. Retention percentage on monthly progress payments to be no greater than the percentage retained by the Owner on its payments to the Contractor. If Owner reduces the retention percentages on payments to the Contractor, the Contractor shall likewise reduce the retention percentage on payments to Cal Stripe.
5. Full retention to be released no later than thirty (30) days after completion of Cal Stripe's extra work regardless of payment by the Owner
6. Any required Testing, Engineering, Design, Permits, Licenses or Applications, and the like to be provided by others.
7. Prices are based on Plans & Specifications available at bid time, including all addenda.
8. All changes to the original scope of work or proposed extra work must be directed by the Contractor in writing prior to Cal Stripe performing this work.
9. For the purpose of this Subcontract Quotation one (1) move-in is considered to be a period of consecutive eight (8) hour days of continuous work, not including weekends and holidays. Any discontinuities in this period, other than weekends and holidays, or for our own convenience, will be charged as an additional move-in at the Addition Move-in Charge as quoted herein.
10. Traffic control plans are not included.
11. If Contractor requires a Bond, the Prime Contractor shall pay for the cost of the bond.
12. Cal Stripe carries \$5,000,000.00 of insurance coverage only. Additional coverage's required by Prime to be paid by Prime Contractor.
13. Items or Processes Not Specifically Included Are Considered To Be Excluded.



May 31, 2019

Willdan Engineering
13191 Crossroads Parkway North, Suite 405
Industry, CA 91746

Attn: Barry Knutson, Construction Manager

Re: 2017/18 Annual Street Overlay Project, City Project Number. 180804
Change Order Request – Credit for Replacement of IISNS With Reflective Street Name Sign

Dear Barry:

Matich Corporation respectfully submits this correspondence as a change order request crediting bid item 23 "Install IISNS ON Signal Mast Arm" located on Project Site 2. RFI number 2 was issued with questions involving the interior illuminated street name sign to be placed at Merrill and Cedar. The response to utilize a reflective sign rather than an IISNS requires a credit for the sign. The credit is for the cost difference between the two sign types, which is \$1,970.00 as the attached backup shows. Please prepare a credit change order in the amount of (\$1,970.00) for this change.

Please do not hesitate to contact me with questions.

Respectfully,

Matich Corporation

A handwritten signature in black ink, appearing to read 'J. Reade', is written over the company name.

by Jake Reade

Copy: File

Bcc:

Attachments: RFI Number 2 and Response, Credit Backup Information



Lic # 822450, C10

PROJECT CHANGE ORDER WORKSHEET

Job Name:	Annual Street Overlay Project - Rialto	Client Job#	18-049
CO Description:	Deductive Change Order for Sign Type Change	MSL Job #	6668
CO Request #:	1	Date:	5/28/19
Contact Name:	Morgan Rierson	Phone #:	(909) 455-0187
E-Mail	mrierson@matchcorp.com		

Item #	Description of Work	Quantity	Unit	Unit Price	Extension
1	Deductive Change Order for Sign Type Change	1		(\$1,970.00)	(1,970.00)
				Grand Total	<u>\$(1,970.00)</u>

Extra Contract
Days Required: _____

EXCLUSIONS: Per original quote and contract.

Prepared by: **David Taft**



CHANGE ORDER REQUEST WORKSHEET

JOB NAME: <u>Annual Street Overlay Project - Rialto</u>	Client JOB# <u>18-049</u>
CCO Description: <u>Deductive Change Order for Sign Type Change</u>	MSL Job # <u>6668</u>
	Date: <u>May 28, 2019</u>
	CCO Request #: <u>1</u>

#	Material	Qty	U/P	U/M	Extension
1	Internally Illuminated Sign	1	(2,470.00)	e	-2,470.00
2	Reflective Sign	1	500.00	e	500.00
Totals					-1,970.00
			Sales tax	0.00%	0.00
Total Material					-1,970.00
Equipment					0.00
			Mark-Up	0%	0.00
Total Equipment					0.00
Total Material & Equipment					-1,970.00
Total Labor					0.00
GRAND TOTAL					(\$1,970.00)

Labor Hours		
Hours		0.00
Rate		\$0.00
Sub-Total		0.00
		0.00
Direct Labor		\$0.00
Mark-Up	20%	\$0.00
Total Labor		\$0.00

Equipment	Hours	Rate		Total
Total				\$0.00



QUOTATION

Estimator: Shellie Campbell

Quote #: SCC101118A

(760)734-5031

Agency: Rialto City of

scampbell@mccain-inc.com

Job Name: 2017/18 Annual Street Overlay Project

Bid Date: 10/11/18

Bid Item	Qty	Description	Price	Extension
SCHED. B		<i>Merrill Ave at Cedar Ave</i>		
23	1	Edge-Lit LED ISNS with mounting brackets to install on existing SMA.	\$2,470.00	\$2,470.00

NO other material is included with this bid

Current lead-time is 6-8 weeks for delivery. Lead-times are subject to change without notice.

This quote valid for 90 days and will Expire on January 9, 2019

Reference Total \$2,470.00

Prices firm for 90 days. Freight included. Add sales tax.

Sale is subject to McCain's standard terms and conditions.

The information transmitted is intended only for the person or entity to which it is addressed and may contain confidential and/or legally privileged material. Any review, retransmission, dissemination or other use of, or taking of any action in reliance upon, this information by persons or entities other than the intended recipient is prohibited.

If you received this in error, please contact the sender and delete the material from any computer.



GEXPRO
 2099 S. STATE COLLEGE BLVD
 SUITE 200
 ANAHEIM, CA 92806

CHANGE ORDER QUOTE

This Quotation supercedes all previous quotations and agreements relating to this transaction. Unless otherwise stated on this document: (i) Our quotation for your use in submitting a job or project bid to your customer expires 30 days from the date hereof, and may be withdrawn earlier by us if prior to acceptance of your bid. (ii) All other quotations are subject to price increases in effect through time or shipment.

To: MSL ELECTRIC
 ATTN: David

From: Karina Chavez
 Phone#: 714-712-8526
 Fax#: 714-712-8517
 Date: 5/28/2019

Job: 6668 Rialto

Re: RFQ

QTY	TYPE	DESCRIPTION	UNIT PRICE	EXTENDED TOTAL
1	SIGN	<p>RSNS "Merrill Ave" With Safety Cables</p> <p><i>Lead times are approximate, and not guaranteed. We cannot guarantee any dates provided, especially when outside factors, such as vendored material (i.e, current worldwide ballast shortage) may delay production / shipment. Also be advised, we also cannot guarantee availability of stock quantities, as these quantities change throughout each day, as orders are processed nationwide.</i></p> <p>PLEASE FAX BACK THE FOLLOWING WRITTEN CONFIRMATION TO PROCEED WITH ORDER: PO / REF # _____ SIGNED _____ DATE _____</p>	\$ 500.00	\$ 500.00
Total:				\$ 500.00

All sales transactions are subject to credit approval. Any quotation and all transactions with Gexpro are conditioned upon Gexpro's Terms and Conditions of Sale located at <https://www.gexpro.com/usg/termsAndConditions>. Quotation is valid for 30 days after the date of issue unless otherwise specified. Items subject to governmental tariffs effective on or after quotation will be price in effect at time of shipment unless otherwise specified. Proposal doesn't include tariffs going into effect 5/15/19. Quotation for commodity items is valid for the day of the quote only unless otherwise specified. All amounts quoted do not include state, local or municipal taxes. Taxes are added at time of sale.

RFI #2 – Merrill Street Name Sign

Due
Mar 14, 2019

Sent on
Mar 07, 2019

Sent by
Jake Reade

Assigned to

»**Jake Reade** jreade@matichcorp.com
»**Morgan Rier-son** mrierson@matichcorp.com

Question

Please see the attached RFI from MSL regarding the Street Name Sign for Merrill. Information required is as follows:

1. City Logo for SNS needed in AI or EPS format
2. Confirm whether the SNS is to be LED internally illuminated or reflective? The plans refer to City Standard TS-403 and to match the other signs at the intersection. TS-403 refers to reflective signs, and the existing signs are also reflective.
3. The black color shown in the artwork is the frame of the sign. Does the City want the frame in another color?

Answer

References (0)

Jake Reade

From: Jeffrey Schafer <jschafer@rialto.ca.gov>
Sent: Thursday, March 14, 2019 5:08 PM
To: Jake Reade; bknutson@willdan.com
Cc: Kelly Koleszar; Morgan Rierson; Robert Del Toro; Chris Baca; dtaft@mslelectric.com; Azzam Jabsheh
Subject: RE: Project 180804 - Response to RFI No. 2
Attachments: City Fruit Logo.PNG; Existing Merrill Ave Sign.docx; Gexpro_SNS Layout Rev. 2, 11.14.18.pdf

City Response to RFI #2 – Merrill Street Name Sign

Question 1. City Logo for SNS needed in AI or EPS format.

Response 1. The City does have the logo in AI or EPS formats. Please see attached City Logo in PNG format.

Question 2. Confirm whether the SNS is to be LED internally illuminated or reflective? The plans refer to the City Standard TS-403 and to match the other signs at the intersection. TS-403 refers to reflective signs, and the existing signs are also reflective.

Response 2. The City wants to have the new sign match the existing signs. Therefore, the new sign should be reflective type, conforming to TS-403. See attached photo of one of the existing signs. Also see attached Gexpro submittal as an example of a similar sign that meets City requirements. Please note that the City requires a sign safety cable as indicated in the Gexpro submittal.

Question 3. The black color shown in the artwork is the frame of the sign. Does the City want the frame in another color?

Response 3. The frame color should be white, matching the existing signs, and similar to the Gexpro submittal sample.

Additional Comment: This sign is item 23 on Bid Schedule B, and is specified as an internally illuminated sign. Because of the change to a reflective sign there should be a cost reduction. Please provide a revised cost for the reflective type sign.

Thank you.

Jeffrey T. Schafer, P.E.
Associate Civil Engineer
Public Works Department

CITY OF RIALTO

335 W. Rialto Avenue, Rialto, CA 92376

Office: 909-820-2531 | **Email:** jschafer@rialto.ca.gov | **Website:** www.yourrialto.com

CUSTOMER CARE | SAME DAY RESPONSE



BRIDGE TO PROGRESS

From: Jake Reade [mailto:jreade@matichcorp.com]

Sent: Thursday, March 07, 2019 7:52 AM

To: bknutson@willdan.com

Cc: Jeffrey Schafer <jschafer@rialtoca.gov>; Robert G. Eisenbeisz <reisenbeisz@rialtoca.gov>; Kelly Koleszar <kkoleszar@matichcorp.com>; Morgan Rierson <mrierson@matichcorp.com>; Robert Del Toro <rdeltoro@matichcorp.com>; Chris Baca <cbaca@willdan.com>; dtaft@mslelectric.com

Subject: Project 180804

Barry / Jeff,

Please find attached RFI number 2 regarding the Street Name Sign to be installed at Merrill and Cedar.

Thank you,



Jake Reade

Project Manager

jreade@matichcorp.com

cell: 909-228-1658

office: 909-382-7400

P.O. Box 10 Highland, CA 92346

www.matichcorp.com

Please consider the environment before printing this e-mail.

The information in this e-mail and any attachments are for the sole use of the intended recipient and may contain privileged and confidential information. If you are not the intended recipient, any use, disclosure, copying or distribution of this message or attachment is strictly prohibited. If you believe that you have received this e-mail in error, please contact the sender immediately and delete the e-mail and all of its attachments.



REQUEST FOR INFORMATION

Date of Request : February 28, 2019

Project Location : Annual Street Overlay in Rialto - Project # 180804

MSL Job#: 6668

RFI # 1

Person / Company Requesting Information : MSL Electric
4938 E. La Palma Ave.
Anaheim Ca. 92807
714-693-4837

Reason For Request :
Can you have the city provide a copy of the city's logo, preferably in an AI. Or EPS formatted file.
Can you please confirm that this sign is LED internally illuminated or reflective?
The black on the artwork is the frame. Do they want the frame in another color?

Plan / Sheet Reference :
Merrill Avenue Signing and Striping Plan Sheet 12 of 18 per note ST

Possible Resolutions :
The plan note says to match existing street name signs in the intersection and per Rialto spec TS-403. All other signs in the intersection are reflective and not illuminated?

Customer Artwork for Approval



NO. 1912

SIGN/A
Double Sided
Qty: 1



1.6" Radius, 0.3" Edges, White on Blue;
"Merrill Ave" D 86% spacing;

SIGN FEATURES:

- White Ultra-brite LED Illumination
- Razor Frame / Black Powder 39-80020
- Highway Font
- Letters Height: 8/6 UC/LC ✓
- Back Brace Mount
- Power Connect Depicts Pole Mount Position
- Logo: NA *see TS-403*

BACKGROUND COLOR INFORMATION:
 3M Electrocut Film
 Color: Blue *3M # 1175*

Under Hang Mount



Blw 3M # 1175

*missing logo
City of Rialto logo*

Unless otherwise specified, all letters spacing and width shall be 120% of the U.S. D.O.T. minimum recommendations
Letters shall conform to FHWA's Standard Alphabets for Highway Signs; standard spacing is applied to address, numerals,

Design: TR	Client: JAM Services_City of Rialto	Client PO#: 58833
Date: February 8, 2019	Designer: P. May	Checked by: D. Little
Toll Free: 1-800-633-3221	Customer Approval:	Date:
Fax: 256-353-4578		
Sales: adrian.baker@temple-mc.com		
www.TempleEdge.net.com		

Disclaimer: Any Original Work is protected under Federal Copyright Law. Any reproduction may be made of original design. This product and its representation actual colors may vary slightly due to lighting conditions.

Copyright © 2014 Temple, Inc. All rights reserved.
 Page 1 of 1

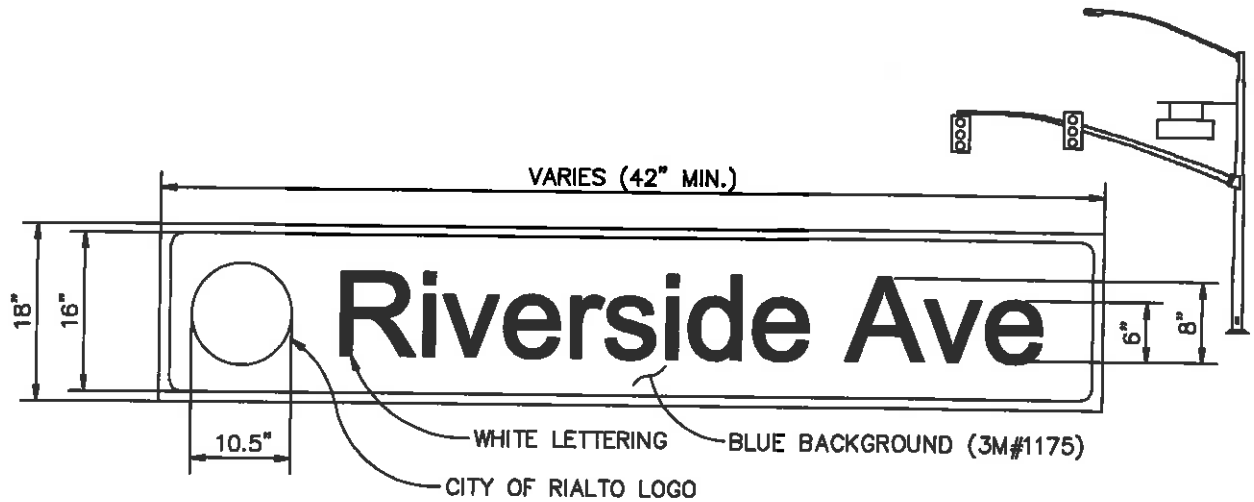

NOTES:

1. CANTILEVER ARM MOUNTED REFLECTORIZED STREET NAME SIGNS SHALL BE TYPE DG3.
2. SIGN PANEL SURFACES, INCLUDING LETTERING AND BORDERS, SHALL BE 3M BRAND DIAMOND GRADE (DG3 4090) REFLECTIVE SHEETING AND MEET ASTM TYPE XI SPECIFICATIONS. REFLECTIVE SHEETING SHALL BE APPLIED IN SUCH A MANNER AS TO MAINTAIN LIGHT TRANSMISSION LEVELS SPECIFIED IN THE CALTRANS SPECIFICATIONS.
3. SIGN LEGENDS SHALL BE WHITE ON BLUE, MINIMUM SIGN PANEL WIDTH SHALL BE 42". DETAILS OF COLOR, STYLE, BORDERS, AND SPACING SHALL CONFORM TO CITY OF RIALTO STANDARD PLAN AS SHOWN ABOVE.
4. "PERIODS" SHALL NOT BE USED ON ABBREVIATIONS. FULL-SIZE LAYOUTS FOR EACH LEGEND SHALL BE SUBMITTED TO THE ENGINEER FOR APPROVAL PRIOR TO FABRICATION.
5. CANTILEVER ARM MOUNTED STREET NAME SIGNS SHALL BE INSTALLED ON POLES AT THE LOCATIONS SHOWN ON THE PLANS. THE STREET NAME SIGNS AND MOUNTING HARDWARE SHALL BE FURNISHED BY THE CONTRACTOR. THE SIGN LEGENDS ARE SHOWN ON THE TRAFFIC SIGNAL PLANS. THE HANGER ASSEMBLY SHALL BE PER SHEET 2. THE SIGN PANEL SHALL BE LEVELED AND ALL HARDWARE TIGHTENED SECURELY.
6. SIGN INSTALLATION ASSEMBLY SHALL BE WARRANTED FOR 1 YEAR MINIMUM FOR ANY DEFECTS AND MALFUNCTIONS.

NOT TO SCALE

		<p>APPROVED BY:  _____ DATE 6/28/16</p>	<p>TRAFFIC SIGNAL STREET NAME SIGN</p>		
		<p>REVISIONS</p>			
DATE	BY	MARK	APPROVED	<p>CITY OF RIALTO, CALIFORNIA PUBLIC WORKS DEPARTMENT ENGINEERING DIVISION</p>	
		<p>STANDARD NO. TS-403</p>	<p>SHT 1 OF 2</p>		

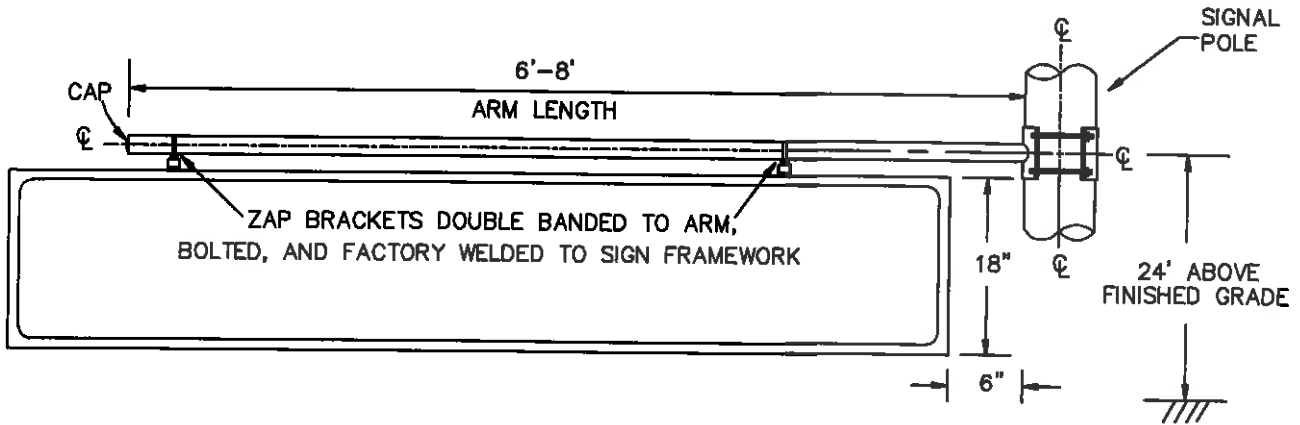

SIGN MOUNT DETAIL

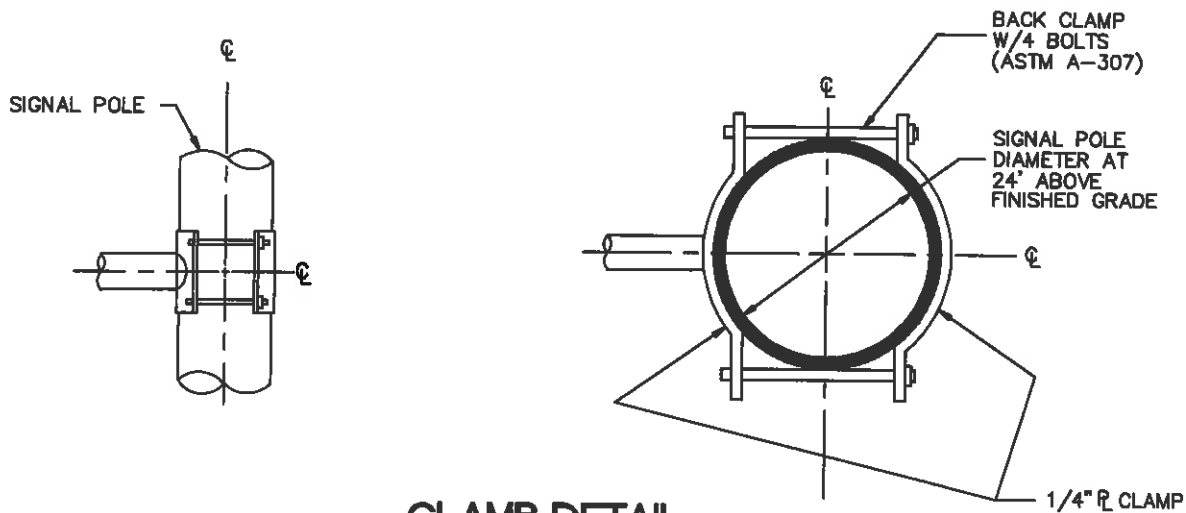

CLAMP DETAIL

NOT TO SCALE

APPROVED BY:

 P.W. DIRECTOR/CITY ENGINEER 6/28/16
 DATE

**TRAFFIC SIGNAL
 STREET NAME SIGN**

REVISIONS			
DATE	BY	MARK	APPROVED

**CITY OF RIALTO, CALIFORNIA
 PUBLIC WORKS DEPARTMENT
 ENGINEERING DIVISION**

STANDARD NO. TS-403 SHT 2 OF 2

S.C. SIGNS & SUPPLIES 877-731-7446 CODE: RSNNS



Pacific Electric Tr

CUSTOMER: GEXPRO
P.O.
CITY OF RIALTO SPECS
HOUSING: RSNS SG TYPE 96 X 18
PANEL TYPE: ALUMINUM .063
REFLECTIVE MATERIAL: 3M DIAMOND GRADE

BORDERS: 1 INCH - 1 RADIUS CORNERS
FONT TOP LINE: 8in UC 6in LC
SAFETY CABLES: EYE BOLT
HARDWARE: ZAP 1000

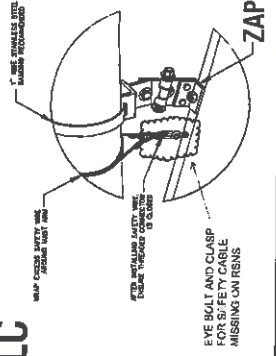



CCO No. 2, Item
No. 5

August 5, 2019

Willdan Engineering
13191 Crossroads Parkway North, Suite 405
Industry, CA 91746

Attn: Barry Knutson, Construction Manager

Re: 2017/18 Annual Street Overlay Project, City Project Number. 180804
Change Order Request 7.01 – Relocate Project Information Signs on Linden

Dear Barry:

Matich Corporation respectfully submits this correspondence as a change order request to relocate the southbound project information signs on Linden Avenue as directed by the City. The project information sign locations were laid out in the field prior to installation. Following installation complaints were received regarding the signs by the owner of the apartment building on the southwest corner of Linden and Foothill. Matich was directed to relocate the sign from the original location. Please prepare a contract change order in the amount of \$635.61 for this work performed as directed.

Please do not hesitate to contact me with questions.

Respectfully,

Matich Corporation

A handwritten signature in black ink, appearing to read 'J. Reade', is written over the company name.

by Jake Reade

Copy: File

Bcc:

Attachments:

DAILY EXTRA WORK REPORT

City Of Rialto

Contractor Job: 18-049 - 2017/18 Annual Street Overlay Project

Contract: 180804

Work Performed By: Match Corporation

 Change Order **100**

Description of Work: Relocate Project Funding Signs On Linden Southbound As Directed By Barry K.

 Billing Number **1.0**

 Report Date **2/25/2019**

 Perform Date **2/25/2019**
Labor Charges

Craft/Level	Employee Name	RT Hrs	OT Hrs	Subs Units	RT Rate	OT Rate	Subs Rate	Extended
L01 OE OF8	RF Del Toro	2.00			83.340			166.68
L02 LBR LG4	M Carranza	2.00			63.600			127.20
L03 LBR LG2	W Lopez	2.00			61.250			122.50

Labor Charges

RT Labor 416.38

OT Labor 0.00

Subtotal Labor 416.38

Subsistence 0.00

Other Expenses 0.00

 MU 20.00% 83.28
Labor Total 499.66
Equipment Charges

Equipment ID	Class	Make	Model	A1	A2	RT Hrs	OT Hrs	RT Rate	OT Rate	Delay Factor	Extended
E01 7255	TRUCK	T&TT	06-12			2.00		24.980			49.96
E02 7271	TRUCK	T&TT	12-20			2.00		32.480			64.96

Equipment Charges

Subtotal 114.92

 MU 15.00% 17.24
Equipment Total 132.16
Material Charges
Activity Total 631.82
Bill Surcharge

Bonding 0.60% 3.79

Work Total 635.61
Bill Subtotal 635.61
Bill Total + 635.61
For Owner/Resident Engineer's Use Only
 New Bill Approved for Payment

Date of Action:

 Resubmittal Returned for Correction

Date Received:

Accepted:

Customer:

Date:

Contractor:

Date:

EXTRA WORK REPORT

CHANGE ORDER NUMBER _____

JOB NUMBER 18-049

WORK PERFORMED BY Matich Corp.

DATE PERFORMED 2/25/19

DESCRIPTION OF WORK
Relocate project funding sign on Linden Southbound as directed by Barry K.

DATE OF REPORT 3/4/19

EQUIPMENT

EQP. NO.	MAKE	MODEL	HOURS	RATE	AMOUNT
7-255	Ford	F-250	2		
7-271	Ford	F-550	2		
SUBTOTAL					
MARK-UP					
TOTAL (A)					

LABOR

CRAFT	INT	NAME	REG	HOURS		RATE	EXTENDED TOTAL
				RATE	OT		
OF-8	R	Del Toro	2				
L-4	M	Carranza	2				
L-2	W	Lopez	2				
SUBTOTAL							
LBR BURDEN							
SUBSISTENCE							
LBR MARK-UP							
TOTAL (B)							

MATERIAL and/or WORK done by specialists or LUMP SUM or UNIT PRICE PAYMENTS:

VENDOR	INVOICE NO.	DATE	DESCRIPTION	UNITS	UNIT COST OR NET PAY	EXTENDED TOTAL
SUBTOTAL						
MARK-UP						
TOTAL (A)						

WORK AUTHORIZED BY: _____

Robt Alton

OFFICE USE ONLY

OWNER'S REPRESENTATIVE

MATICH'S REPRESENTATIVE

TOTAL (A + B + C)



CCO No. 2, Item
No. 6

August 5, 2019

Willdan Engineering
13191 Crossroads Parkway North, Suite 405
Industry, CA 91746

Attn: Barry Knutson, Construction Manager

Re: 2017/18 Annual Street Overlay Project, City Project Number. 180804
Change Order Request 7.02 – Pothole Unmarked Drain on Merrill Avenue at Larch Avenue

Dear Barry:

Matich Corporation respectfully submits this correspondence as a change order request to pothole an unmarked storm drain on Merrill Avenue and Larch Avenue as directed by the City. Following pothole operations of utilities, an unmarked storm drain was witnessed that could have potentially conflicted with the design construction of Merrill Avenue and concrete improvements. Exploratory potholing was performed to locate, measure, and tie out the unmarked storm drain for the City's use in determining design and potential conflict. Please prepare a contract change order in the amount of \$293.71 for this work performed as directed.

Please do not hesitate to contact me with questions.

Respectfully,

Matich Corporation

A handwritten signature in black ink, appearing to read 'Jake Reade', is written over a white background.

by Jake Reade

Copy: File

Bcc:

Attachments:

DAILY EXTRA WORK REPORT

City Of Rialto	Contract: 180804	Change Order 100
Contractor Job: 18-049 - 2017/18 Annual Street Overlay Project		Billing Number 2.0
Work Performed By: Matich Corporation		Report Date 3/13/2019
Description of Work: Pothole Location & Depth Of Unmarked Drain On Merrill Ave At Larch Ave		Perform Date 3/13/2019

Labor Charges										Labor Charges	
Craft/Level	Employee Name	RT Hrs	OT Hrs	Subs Units	RT Rate	OT Rate	Subs Rate	Extended			
L01 LBR LG3	J Cariota	2.00			61.870			123.74		RT Labor	123.74

Equipment Charges											
Equipment ID	Class	Make	Model	A1	A2	RT Hrs	OT Hrs	RT Rate	OT Rate	Delay Factor	Extended
E01 7275	TRUCK	T&TT	12-20			2.00		32.480			64.96
E02 21070	AIRCP	PORT	025-045			2.00		29.900			59.80

OT Labor	0.00
Subtotal Labor	123.74
Subsistence	0.00
Other Expenses	0.00
MU 20.00%	<u>24.75</u>
Labor Total	148.49
Equipment Charges	
Subtotal	124.76
MU 15.00%	<u>18.71</u>
Equipment Total	143.47

Material Charges	

Activity Total	291.96
Bill Surcharge	
Bonding 0.60%	1.75
Work Total	293.71
Bill Subtotal	293.71

For Owner/Resident Engineer's Use Only			Accepted:		
<input type="checkbox"/> New Bill	<input type="checkbox"/> Approved for Payment	Date of Action:	Customer:		Date:
<input type="checkbox"/> Resubmittal	<input type="checkbox"/> Returned for Correction	Date Received:	Contractor: <i>Jalen</i>		Date: <i>4/20/19</i>
					Bill Total + 293.71

EXTRA WORK REPORT

JOB NUMBER 18-049
 DATE PERFORMED 3-13-19
 DATE OF REPORT 3-13-19

CHANGE ORDER NUMBER _____

WORK PERFORMED BY Matich Corp.

DESCRIPTION OF WORK Pothole location and depth of Unmarked drain on Merrill at Larch. Drain runs North/South on the Eastside of Per Barry K. Larch

EQUIPMENT

EQP. NO.	MAKE	MODEL	HOURS	RATE	AMOUNT
7-275	Ford	F-350	2		
21-070	Compressor		2		
				SUBTOTAL	
				MARK-UP	
				TOTAL (A)	

LABOR

CRAFT	INT	NAME	REG	HOURS	RATE	OT	RATE	EXTENDED TOTAL
L-3	J	Cariota	2					
								SUBTOTAL
								LBR BURDEN
								SUBSISTENCE
								LBR MARK-UP
								TOTAL (B)

MATERIAL and/or WORK done by specialists or LUMP SUM or UNIT PRICE PAYMENTS:

VENDOR	INVOICE NO.	DATE	DESCRIPTION	UNITS	UNIT COST OR NET PAY	EXTENDED TOTAL
						SUBTOTAL
						MARK-UP
						TOTAL (A)

WORK AUTHORIZED BY: _____
 OWNER'S REPRESENTATIVE

Robert A. Brown
 MATICH'S REPRESENTATIVE

OFFICE USE ONLY

TOTAL (A + B + C) _____



CCO No. 2, Item
No. 7

August 5, 2019

Willdan Engineering
13191 Crossroads Parkway North, Suite 405
Industry, CA 91746

Attn: Barry Knutson, Construction Manager

Re: 2017/18 Annual Street Overlay Project, City Project Number. 180804
Change Order Request 7.03 – Re-Saw Cut Existing PCC Ramps

Dear Barry:

Matich Corporation respectfully submits this correspondence as a change order request to re-saw cut existing concrete ramps and sidewalk as directed. Prior to saw cutting the existing concrete ramps on the project, layout was performed and approved by the City. Saw cutting was the performed after which time it was determined that the locations saw cut would not be sufficient to meet compliance parameters and existing conditions. Please prepare a contract change order in the amount of \$1,529.38 for this work performed as directed.

Please do not hesitate to contact me with questions.

Respectfully,

Matich Corporation

A handwritten signature in black ink, appearing to read 'J. Reade', is written over the printed name 'Matich Corporation'.

by Jake Reade

Copy: File

Bcc:

Attachments:

DAILY EXTRA WORK REPORT

City Of Rialto Contractor Job: 18-049 - 2017/18 Annual Street Overlay Project Work Performed By: Match Corporation Description of Work: Re-Saw Ramps That Were Laid Out Incorrectly	Contract: 180804	Change Order: 100 Billing Number: 3.0 Report Date: 3/19/2019 Perform Date: 3/19/2019
---	------------------	---

Labor Charges								
Craft/Level	Employee Name	RT Hrs	OT Hrs	Subs Units	RT Rate	OT Rate	Subs Rate	Extended
L01 LBR LG2	M Ramirez, Jr.	5.00			61.250			306.25

Equipment Charges								
Equipment ID	Class	Make	Model	A1	A2	RT Hrs	OT Hrs	Extended
E01 7269	TRUCK T&TT		12-20			5.00		162.40

Material/Specialist Work/Lump Sum or Unit Price Payment					
Number	Date	Vendor Name and Description	Units	Unit Price	Extended
M01 20193167	3/19/2019	Spartan Concrete & Asphalt Cutting, Inc. / Concrete Saw	1,000 LS	840.00000	840.00

Labor Charges	
RT Labor	306.25
OT Labor	0.00
Subtotal Labor	306.25
Subsistence	0.00
Other Expenses	0.00
MU 20.00%	<u>61.25</u>
Labor Total	367.50

Equipment Charges	
Subtotal	162.40
MU 15.00%	<u>24.36</u>
Equipment Total	186.76

Material Charges	
Subtotal	840.00
MU 15.00%	<u>126.00</u>
Material Total	966.00

Activity Total 1,520.26

Bill Surcharge		
Bonding	0.60%	9.12

Work Total 1,529.38

Bill Subtotal 1,529.38

Bill Total + **1,529.38**

For Owner/Resident Engineer's Use Only			
<input type="checkbox"/> New Bill	<input type="checkbox"/> Approved for Payment	Date of Action:	
<input type="checkbox"/> Resubmittal	<input type="checkbox"/> Returned for Correction	Date Received:	

Accepted:	
Customer:	Date: _____
Contractor:	Date: <u>6/20/19</u>

Spartan Concrete & Asphalt Cutting, Inc.

Invoice

Flat Sawing - Wall Sawing - Coring - Demolition - Skidsteers - GPR Scanning

20193157

Mailing Address:
P.O. Box 1763, Palm Springs, CA 92263-1763
760-251-8095

Cont. Lic. # 683437 FIN # 33-0958643
Laborers Union Local 1184 DIR Contr. Reg.# 1000011594

Date of Service: 3/19/2019

P.O. / Job#: 18-049

Customer:

Jobsite: YUCCA X MERRILL

MATCH CORPORATION
P.O. BOX 10
HIGHLAND, CA 92346

RECEIVED

RIALTO

MAR 21 2019

gkleepies@matchcorp.com

MATCH CORP.

Customer is responsible for ensuring Spartan is provided with all Public Works Information.

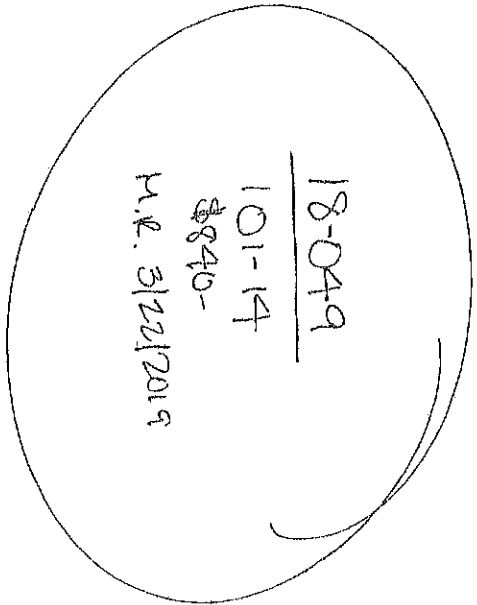
Description of Work Completed	Charge
1 - FLATSAW 41 LF X 4 IN THICK ASPHALT	
2 - FLATSAW 95 LF X CONCRETE SPANDROL	
3 - RESIDUE CLEANUP / WASHOUT ONSITE	
CHARGE OPERATOR: 5.0 HR @ \$ 140.00 PER HR	700.00
CHARGE MOBILIZATION: (1) @ \$ 140.00	140.00
	
Terms: Due on receipt	TOTAL AMOUNT DUE:
Invoices not paid within terms of agreement are subject to a finance charge of 2.0% per month. In the event of default, customer shall be responsible to pay all necessary and reasonable collection costs and expenses incurred, including attorney's fees.	\$840.00

PLEASE NOTE INVOICE NUMBER ON PAYMENT CHECK/STUB.
We accept eCHECKS / MASTERCARD / VISA / AMERICAN EXPRESS
JOINT CHECKS ACCEPTED WITH ACCOMPANYING SIGNATURE GUARANTEE ONLY.

Operator:

SB POSTED

Please add accounting@spartanconcretecutting.com AND admin@spartanconcretecutting.com to your contacts
to receive your invoices and statements
Thank you!



CCO No. 2, Item
No. 8

August 5, 2019

Willdan Engineering
13191 Crossroads Parkway North, Suite 405
Industry, CA 91746

Attn: Barry Knutson, Construction Manager

Re: 2017/18 Annual Street Overlay Project, City Project Number. 180804
Change Order Request 7.04 – Purchase Traffic Signal Pull Boxes

Dear Barry:

Matich Corporation respectfully submits this correspondence as a change order request to furnish 5 each new 17" x 30" traffic signal pull boxes, covers and hardware to replace those damaged prior to construction as directed by the City. These pull boxes existed in concrete ramp locations that were scheduled to be re-constructed as a part of the project. Please prepare a contract change order in the amount of \$650.11 for this work performed as directed.

Please do not hesitate to contact me with questions.

Respectfully,

Matich Corporation

A handwritten signature in black ink, appearing to read 'J. Reade', is written over a white background.

by Jake Reade

Copy: File

Bcc:

Attachments:

DAILY EXTRA WORK REPORT

City Of Rialto Contractor Job: 18-049 - 2017/18 Annual Street Overlay Project Work Performed By: Matich Corporation Description of Work: Purchase 5 Traffic Boxes As Directed By Barry K.	Contract: 180804	Change Order 100 Billing Number 4.0 Report Date 4/02/2019 Perform Date 3/21/2019
---	-------------------------	---

Material/Specialist Work/Lump Sum or Unit Price Payment					
Number	Date	Vendor Name and Description	Units	Unit Price	Extended
M01 5126920	3/21/2019	Cal-Duct Inc. / Concrete Pull Box	1.000 LS	561.94000	561.94

Labor Charges	
Equipment Charges	
Material Charges	
Subtotal	561.94
MU 15.00%	<u>84.29</u>
Material Total	646.23
Activity Total	646.23
Bill Surcharge	
Bonding 0.60%	3.88
Work Total	650.11
Bill Subtotal	650.11

<p style="text-align: center;">For Owner/Resident Engineer's Use Only</p> <table style="width: 100%;"> <tr> <td><input type="checkbox"/> New Bill</td> <td><input type="checkbox"/> Approved for Payment</td> <td>Date of Action:</td> </tr> <tr> <td><input type="checkbox"/> Resubmittal</td> <td><input type="checkbox"/> Returned for Correction</td> <td>Date Received:</td> </tr> </table>	<input type="checkbox"/> New Bill	<input type="checkbox"/> Approved for Payment	Date of Action:	<input type="checkbox"/> Resubmittal	<input type="checkbox"/> Returned for Correction	Date Received:	Accepted: Customer: Date: _____ Contractor: Date: 5/8/19
<input type="checkbox"/> New Bill	<input type="checkbox"/> Approved for Payment	Date of Action:					
<input type="checkbox"/> Resubmittal	<input type="checkbox"/> Returned for Correction	Date Received:					
Bill Total + 650.11							

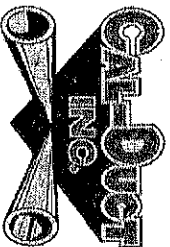

2625 S. Lilac Avenue, Bloomington, CA 92316
 Ph# 909.877.0577, Fax# 909.877.3205

REMIT TO:
 CAL-DUCT, INC.
 P.O. Box 520
 Bloomington, CA 92316

INVOICE

INVOICE	
5126920	
Invoice Date	Page
3/21/2019 13:18:38	1 of 2
ORDER NUMBER	
1143039	

Bill To:
 CASH SALES - BLOOMINGTON
 2625 S. LILAC AVENUE
 BLOOMINGTON, CA 92316

Ship To:
 MATCH CORPORATION
 CUSTOMER WILL CALL
 BLOOMINGTON, CA 92316

18-049
As directed
by the
city.

700-1

Ordered By: Mr. JAKE READE

Customer ID: 100220

M.E. 3/28/2019

PO Number	Term Description	Net Due Date	Disc Due Date	Discount Amount
MATCH CORPORATION	DUE UPON RECEIPT	3/21/2019	3/21/2019	0.00
Order Date	Pick Ticker No	Primary Salesrep Name	Taker	
3/21/2019 05:10:50	3130980	BIM HOUSE ACCOUNT	J.DONALDSON	

Quantities				Hem ID	Hem Description	Pricing UOM	Unit Price	Extended Price
Ordered	Shipped	Remaining	UOM	Unit Size	Disp.	Unit Size		

Delivery Instructions: ***WILL CALL****

Carrier: Will Call

Tracking #:

5	5	0 EA	1.0	OLDN36BOX	17x30 Concrete Pull Box x 12in Deep	EA	51.0000	255.00
SKU: 1000155 Oldcastle Precast Enclosure Solutions								
5	5	0 EA	1.0	OLDN36RTS	CHRISTY 17x30 Concrete Lid TRAFFIC SIGNAL Bolt Down (Hardware sold SEPARATELY)	EA	49.0000	245.00
10	10	0 EA	1.0	OLDN90WASH	3/8" Stainless Steel Flat Washer	EA	0.3000	3.00
10	10	0 EA	1.0	OLDN90BOLT	HEX Head 3/8"-16 x 2-1/2" SS Bolt	EA	1.0000	10.00
10	10	0 EA	1.0	OLDN90NUT	Speed Nutr 3/8"-16 Single Thread	EA	0.8500	8.50

POSTED

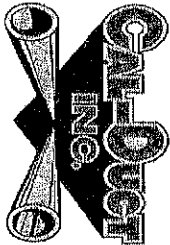

2625 S. Lilac Avenue, Bloomington, CA 92316
 Ph# 909.877.0577, Fax# 909.877.3205

REMIT TO:
 CAL-DUCT, INC.
 P.O. Box 520
 Bloomington, CA 92316

INVOICE

INVOICE	
5126920	
Invoice Date	Page
3/21/2019 13:18:58	2 of 2
ORDER NUMBER	
1143039	

Quantities				Item ID	Item Description	Pricing UOM	Unit Size	Unit Price	Extended Price
Ordered	Shipped	Remaining	UOM Unit Size						

Card: MASTERCARD
 Tran Type: Final Sale
 Name: JAKE READE
 Account Number: 3950
 Authorization Number: 096631
 Reference Number: 56942
 Batch Number: 448
 Merchant ID: 498266994884
 Authorization Amount: 561.94
 Retrieval Number: 569261640

X _____
 I agree to pay above total amount
 according to card issuer agreement

Total Lines: 5

SUB-TOTAL:	521.50
CALIF STATE TAX:	37.82
SAN BERNARDINO COUNTY TAX:	2.62
MASTERCARD:	561.94
AMOUNT DUE:	0.00



CCO No. 2, Item
No. 9

August 5, 2019

Willdan Engineering
13191 Crossroads Parkway North, Suite 405
Industry, CA 91746

Attn: Barry Knutson, Construction Manager

Re: 2017/18 Annual Street Overlay Project, City Project Number. 180804
Change Order Request 7.05 – Construct 3' Ribbon Gutter Behind Approach on Rialto Avenue

Dear Barry:

Matich Corporation respectfully submits this correspondence as a change order request to construct a 3' ribbon gutter on Rialto Avenue behind the approach on Rialto Avenue as directed by the City. No bid item existed to apply this type of work to. Please prepare a contract change order in the amount of \$658.00 for this work performed as directed.

Please do not hesitate to contact me with questions.

Respectfully,

Matich Corporation

A handwritten signature in black ink, appearing to read 'Jake Reade', is written over the printed name.

by Jake Reade

Copy: File

Bcc:

Attachments:

DAILY EXTRA WORK REPORT

City Of Rialto Contractor Job: 18-049 - 2017/18 Annual Street Overlay Project Work Performed By: Matich Corporation Description of Work: Place 3' Ribbon Gutter Behind Approach		Contract: 180804	Change Order 100 Billing Number 5.0 Report Date 4/15/2019 Perform Date 4/15/2019																											
Labor Charges			Labor Charges																											
<table border="1" style="width: 100%; border-collapse: collapse;"> <thead> <tr> <th>Craft/Level</th> <th>Employee Name</th> <th>RT Hrs</th> <th>OT Hrs</th> <th>Subs Units</th> <th>RT Rate</th> <th>OT Rate</th> <th>Subs Rate</th> <th>Extended</th> </tr> </thead> <tbody> <tr> <td>L01</td> <td>CMTMS LG5 J Perez</td> <td>3.00</td> <td></td> <td></td> <td>66.360</td> <td></td> <td></td> <td>199.08</td> </tr> <tr> <td>L02</td> <td>CMTMS LG5 E Olivera</td> <td>3.00</td> <td></td> <td></td> <td>66.360</td> <td></td> <td></td> <td>199.08</td> </tr> </tbody> </table>	Craft/Level	Employee Name	RT Hrs	OT Hrs	Subs Units	RT Rate	OT Rate	Subs Rate	Extended	L01	CMTMS LG5 J Perez	3.00			66.360			199.08	L02	CMTMS LG5 E Olivera	3.00			66.360			199.08			RT Labor 398.16 OT Labor 0.00
Craft/Level	Employee Name	RT Hrs	OT Hrs	Subs Units	RT Rate	OT Rate	Subs Rate	Extended																						
L01	CMTMS LG5 J Perez	3.00			66.360			199.08																						
L02	CMTMS LG5 E Olivera	3.00			66.360			199.08																						
Equipment Charges			Subtotal Labor 398.16 Subsistence 0.00 Other Expenses 0.00																											
<table border="1" style="width: 100%; border-collapse: collapse;"> <thead> <tr> <th>Equipment ID</th> <th>Class</th> <th>Make</th> <th>Model</th> <th>A1</th> <th>A2</th> <th>RT Hrs</th> <th>OT Hrs</th> <th>RT Rate</th> <th>OT Rate</th> <th>Delay Factor</th> <th>Extended</th> </tr> </thead> <tbody> <tr> <td>E01</td> <td>7273</td> <td>TRUCK</td> <td>T&TT</td> <td>12-20</td> <td></td> <td>1.00</td> <td></td> <td>38.380</td> <td></td> <td></td> <td>38.38</td> </tr> </tbody> </table>	Equipment ID	Class	Make	Model	A1	A2	RT Hrs	OT Hrs	RT Rate	OT Rate	Delay Factor	Extended	E01	7273	TRUCK	T&TT	12-20		1.00		38.380			38.38			MU 20.00% <u>79.63</u> Labor Total 477.79			
Equipment ID	Class	Make	Model	A1	A2	RT Hrs	OT Hrs	RT Rate	OT Rate	Delay Factor	Extended																			
E01	7273	TRUCK	T&TT	12-20		1.00		38.380			38.38																			
Material/Specialist Work/Lump Sum or Unit Price Payment			Equipment Charges																											
<table border="1" style="width: 100%; border-collapse: collapse;"> <thead> <tr> <th>Number</th> <th>Date</th> <th>Vendor Name and Description</th> <th>Units</th> <th>Unit Price</th> <th>Extended</th> </tr> </thead> <tbody> <tr> <td>M01</td> <td>107689</td> <td>4/15/2019 Rancho Ready Mix Products, L.P. / 520-C-2500 Mix</td> <td>1.000 CY</td> <td>114.91000</td> <td>114.91</td> </tr> </tbody> </table>	Number	Date	Vendor Name and Description	Units	Unit Price	Extended	M01	107689	4/15/2019 Rancho Ready Mix Products, L.P. / 520-C-2500 Mix	1.000 CY	114.91000	114.91			Subtotal 38.38 MU 15.00% <u>5.76</u> Equipment Total 44.14															
Number	Date	Vendor Name and Description	Units	Unit Price	Extended																									
M01	107689	4/15/2019 Rancho Ready Mix Products, L.P. / 520-C-2500 Mix	1.000 CY	114.91000	114.91																									
			Material Charges																											
			Subtotal 114.91 MU 15.00% <u>17.24</u> Material Total 132.15																											
			Activity Total 654.08																											
			Bill Surcharge																											
			Bonding 0.60% 3.92																											
			Work Total 658.00																											
			Bill Subtotal 658.00																											
For Owner/Resident Engineer's Use Only			Bill Total + 658.00																											
<input type="checkbox"/> New Bill <input type="checkbox"/> Approved for Payment		Date of Action:	Accepted:																											
<input type="checkbox"/> Resubmittal <input type="checkbox"/> Returned for Correction		Date Received:	Customer: _____ Date: _____ Contractor: <i>[Signature]</i> Date: <u>5/8/19</u>																											



RANCHO READY MIX PRODUCTS, LP.

RECEIVED

APR 25 2019

28251 LAKE STREET • LAKE ELSINORE, CA 92530

TEL: (951) 245-2460

MAATCH CORP.

Page: 1

MAATCH CORPORATION
P.O. BOX 10
HIGHLAND, CA 92346

Cust/Job #:
18049-MERRILL & RIVERSIDE
000089 18049-RIALTO & SYCAMORE
RIALTO

CUSTOMER	INVOICE	DATE	TERMS
13068	107689	04/15/2019	10TH OF FOLLOWING MONTH

DESCRIPTION	QUANTITY	UM	PRICE	AMOUNT
-------------	----------	----	-------	--------

Ticket Number 002-128946				
520-C-2500 GREEN BOOK				
FUEL SURCHARGE	1.00	LD	20.00	20.00
PREVALTING WAGE CHARGE	1.00	LD	220.00	220.00
ENVIRONMENTAL FEE	1.00	LD	40.00	40.00

Ticket Number 002-128959				
520-C-2500 GREEN BOOK				
SHORT LOAD	1.00	LD	30.00	30.00
FUEL SURCHARGE	1.00	LD	20.00	20.00
PREVALTING WAGE CHARGE	1.00	LD	220.00	220.00
ENVIRONMENTAL FEE	1.00	LD	40.00	40.00

TOTAL YARDS:	17.00			
JOB TAX				140.59
JOB TOTAL				1954.59

POSTED

18-044

305-5		306-5		308-5
181.39		181.43		114.98
<hr/>				
312-5		700-3		
804.80		114.91		
<hr/>				
M.V. 4/30				

TAXABLE AMOUNT	1,814.00
EXEMPT AMOUNT	0.00
SALES TAX	140.59
INVOICE TOTAL	1,954.59

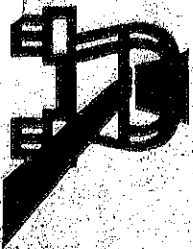

RANCHO READY MIX PRODUCTS, LP

Control Number **570653**

1150 SOUTH RANCHO AVENUE COLTON, CA 92324-5941

TEL: (909) 825-3611

28251 LAKE STREET LAKE ELSINORE, CA 92530

TEL: (951) 674-0488

861 W. 4TH STREET BEAUMONT, CA 92223

TEL: (951) 845-5511

WEIGHMASTER CERTIFICATE

X _____
DEPUTY - SIGNATURE

THIS IS TO CERTIFY that the following described commodity was weighed, measured, or counted by a weighmaster, whose signature is on this certificate, who is recognized authority of accuracy, as prescribed by chapter 7 (commencing with Section 12700) of Division 5 of the California Business and Professions Code, administered by the Division of Measurement Standards of the California Department of Food and Agriculture.

CONCRETE IS A PERISHABLE COMMODITY AND BECOMES THE PROPERTY OF THE PURCHASER UPON LOADING OF THE TRUCK. Any changes or cancellation of the ordered instructions must be telephoned to the plant before loading begins. If necessary to institute legal proceedings for the collection of payment for this material, the buyer agrees to pay all court costs of such suit and such attorney fees as the court may deem just and reasonable. **NO DISCOUNTS** will be allowed and **INTEREST** will be charged on all accounts unpaid by the 10TH OF THE MONTH.

CONCRETE IS A NATURAL PRODUCT therefore we cannot be responsible for variations in color or surface discoloration caused by variations in finishing techniques. We also cannot be responsible for customer supplied mix designs.

WARNING - CONCRETE in a plastic state can be **IRRITATING TO THE SKIN AND EYES.** Concrete contains Portland cement. Wear protective clothing and eyewear such as rubber boots, gloves, and safety glasses. Avoid contact with eyes and skin. **PROLONGED CONTACT MAY CAUSE BURNS.** In case of contact flush thoroughly with water. If irritation persists, get medical attention. **KEEP PLASTIC CONCRETE AWAY FROM THE CHILDREN.**

UNLOADING RELEASE

In consideration of RANCHO READY MIX PRODUCTS, LP, hereinafter referred to as Material Dealer, delivering the purchased material to a place designated by the undersigned, the undersigned hereby releases and agrees to indemnify and hold harmless said Material Dealer, their Agents, employees and drivers from all liability or claims for damages done by it, or them, to sidewalks, driveways, roadway, property and all other real and personal property adjacent thereto, as a result of the movement of said Material Dealer's vehicles or employees upon or about such property. This release is intended to, and does cover all movements of all vehicles of said Material Dealer, while being used in delivering and unloading such purchased material at the location indicated below, from the time such vehicles leave the curb line to enter upon the property described below until they return to such curb line, regardless of the number and/or dates of such deliveries or movements. Claims for shortages will only be allowed at the time the material is delivered.

SIGNATURE: _____

Print Name: _____

PORTLAND CEMENT ASSOCIATION CONSTRUCTION JOINT RECOMMENDATIONS: 4" THICK FLATWORK, PEAS GRAVE MIXES 8" X 8", 1" MIXES 10" X 10" (width spacing for more than a 1 to 1.5 length to width ratio) with joint depths of 1" Isolator joints to all other structures are highly recommended. Call for more information or visit website at www.cement.org.

TO JOB	ARRIVE	START	END	STAND BY	LEAVE	PLANT
250	9:00	9:15	9:45	—	—	—
DATE	TIME	PLANT #	ORDER #	JOB #	ZONE	PO #
12-20-11	09:00	002	025	2002	1	
SOLD TO	TRUCK #	TRUCK #	TRUCK #	TRUCK #	TRUCK #	TRUCK #
RANCHO CORPORATION						
INSTRUCTIONS:	INSTRUCTIONS:	INSTRUCTIONS:	INSTRUCTIONS:	INSTRUCTIONS:	INSTRUCTIONS:	INSTRUCTIONS:

JOB ADDRESS	JOB ADDRESS	JOB ADDRESS	JOB ADDRESS
JOB TIME	SLUMP	USAGE	MARRAGE
BATCH WATER	FREE MOISTURE	MAX WATER	WATER ADDED

TOTAL ORDERED	TOTAL SHIPPED	THIS TICKET	PRODUCT CODE	PRODUCT DESCRIPTION	UNITS	UNIT PRICE	EXTENSION
				CUSTOMER ASSUMES RESPONSIBILITIES FOR WATER ADDED BEYOND DESIGNED SLUMP. NOTICE: Excessive water is detrimental to concrete performance.			
				Print name: _____ Authorized by: _____			
				SUBTOTAL			
				TAX			
				TOTAL			
				PREV. BAL.			
				SUBTOTAL			
				STAND BY			
				TOTAL			



CCO No. 2, Item
No. 10

August 5, 2019

Willdan Engineering
13191 Crossroads Parkway North, Suite 405
Industry, CA 91746

Attn: Barry Knutson, Construction Manager

Re: 2017/18 Annual Street Overlay Project, City Project Number. 180804
Change Order Request 7.06 – Remove Concrete as Directed Beyond ECR at Merrill and Iris

Dear Barry:

Matich Corporation respectfully submits this correspondence as a change order request to remove existing concrete curb and gutter, and concrete sidewalk beyond the ECR at Merrill and Iris as directed. Following layout sawcut and removal operations, Matich was directed to remove additional concrete for ramp compliance. The work was directed following the completion of removals and required re-mobilization to the area to perform. Please prepare a contract change order in the amount of \$657.40 for this work performed as directed.

Please do not hesitate to contact me with questions.

Respectfully,

Matich Corporation

A handwritten signature in black ink, appearing to read 'Jake Reade', is written over the company name.

by Jake Reade

Copy: File

Bcc:

Attachments:

DAILY EXTRA WORK REPORT

City Of Rialto Contractor Job: 18-049 - 2017/18 Annual Street Overlay Project Work Performed By: Match Corporation Description of Work: Remove Curb & Gutter And Sidewalk As Directed Beyond ECR On Merrill At Iris		Contract: 180804	Change Order 100 Billing Number 6.0 Report Date 4/02/2019 Perform Date 3/27/2019																											
Labor Charges <table border="1" style="width: 100%; border-collapse: collapse; margin-top: 5px;"> <thead> <tr> <th>Craft/Level</th> <th>Employee Name</th> <th>RT Hrs</th> <th>OT Hrs</th> <th>Subs Units</th> <th>RT Rate</th> <th>OT Rate</th> <th>Subs Rate</th> <th>Extended</th> </tr> </thead> <tbody> <tr> <td>L01 LBR LG3</td> <td>J Cariota</td> <td>2.00</td> <td></td> <td></td> <td>61.870</td> <td></td> <td></td> <td>123.74</td> </tr> <tr> <td>L02 LBR LG3</td> <td>E Martin</td> <td>2.00</td> <td></td> <td></td> <td>61.870</td> <td></td> <td></td> <td>123.74</td> </tr> </tbody> </table>			Craft/Level	Employee Name	RT Hrs	OT Hrs	Subs Units	RT Rate	OT Rate	Subs Rate	Extended	L01 LBR LG3	J Cariota	2.00			61.870			123.74	L02 LBR LG3	E Martin	2.00			61.870			123.74	Labor Charges RT Labor 247.48 OT Labor 0.00 Subtotal Labor 247.48 Subsistence 0.00 Other Expenses 0.00 MU 20.00% <u>49.50</u> Labor Total 296.98
Craft/Level	Employee Name	RT Hrs	OT Hrs	Subs Units	RT Rate	OT Rate	Subs Rate	Extended																						
L01 LBR LG3	J Cariota	2.00			61.870			123.74																						
L02 LBR LG3	E Martin	2.00			61.870			123.74																						
Material/Specialist Work/Lump Sum or Unit Price Payment <table border="1" style="width: 100%; border-collapse: collapse; margin-top: 5px;"> <thead> <tr> <th>Number</th> <th>Date</th> <th>Vendor Name and Description</th> <th>Units</th> <th>Unit Price</th> <th>Extended</th> </tr> </thead> <tbody> <tr> <td>M01 29243</td> <td>3/27/2019</td> <td>Hixson Backhoe Service Inc / 580 Case Backhoe</td> <td>2.000 HR</td> <td>155.00000</td> <td>310.00</td> </tr> </tbody> </table>			Number	Date	Vendor Name and Description	Units	Unit Price	Extended	M01 29243	3/27/2019	Hixson Backhoe Service Inc / 580 Case Backhoe	2.000 HR	155.00000	310.00	Equipment Charges Material Charges Subtotal 310.00 MU 15.00% <u>46.50</u> Material Total 356.50 Activity Total 653.48 Bill Surcharge Bonding 0.60% 3.92 Work Total 657.40 Bill Subtotal 657.40															
Number	Date	Vendor Name and Description	Units	Unit Price	Extended																									
M01 29243	3/27/2019	Hixson Backhoe Service Inc / 580 Case Backhoe	2.000 HR	155.00000	310.00																									
For Owner/Resident Engineer's Use Only <input type="checkbox"/> New Bill <input type="checkbox"/> Approved for Payment Date of Action: <input type="checkbox"/> Resubmittal <input type="checkbox"/> Returned for Correction Date Received:		Accepted: Customer: _____ Date: _____ Contractor: <i>Jalen</i> Date: 5/8/19	Bill Total + 657.40																											

HIXSON BACKHOE SERVICE INC



INVOICE

PO BOX 715
 MURRIETA, CA 92564-0715
 (951) 677-6212 * FAX (951) 677-3894
 CSLB #9556710 * SB(Micro)



DATE	INVOICE NO.
3/30/2019	29243

BILL TO
 Match Corporation
 P.O. Box 10
 Highland, CA 92346

JOB LOCATION
 Yucca Ave & Merrill Ave
 C/P & Dir #26743B
 Rialto, CA
 APR 15 2019

P.O. NO.	TERMS	JOB #
	30 days	18-049

DATE	DESCRIPTION	TICKET #	HOURS	RATE	AMOUNT
3/25/2019	580 Backhoe W/Operator	36699	8	155.00	1,240.00 ✓
3/28/2019	580 Backhoe W/Operator	36702	8	155.00	1,240.00 ✓
3/29/2019	580 Backhoe W/Operator	36703	8	155.00	1,240.00 ✓
3/25/2019	580 Backhoe W/Operator	37491	8	155.00	1,240.00 ✓
3/26/2019	580 Backhoe W/Operator	37492	8	155.00	1,240.00 ✓
3/27/2019	580 Backhoe W/Operator	37493	8	155.00	1,240.00 ✓
3/28/2019	580 Backhoe W/Operator	37494	8	155.00	1,240.00 ✓
3/29/2019	580 Backhoe W/Operator	37496	8	155.00	1,240.00 ✓
	18-049				
	105-1: \$ 775-	205-3: \$ 1,705-			
	105-3: \$ 310-	206-3: \$ 465-			
	106-1: \$ 155-	209-3: \$ 620-			
	107-1: \$ 155-	210-3: \$ 2,190-			
	108-1: \$ 542.50	101-23: \$ 670-			
	108-3: \$ 930-				
	109-1: \$ 620-	M.L. 417			
	110-1: \$ 232.50				

POSTED

Certified Payroll - Submitted on CA DIR eCPR - Thank You

Total	\$9,920.00
--------------	-------------------

HIXSON BACKHOE SERVICE, INC.
P.O. Box 0715, Murietta, CA 92564-0715 - (951) 677-6212 • FAX (951) 677-3894

№ 37493

WORK FOR

Mattick
17176

PO #

18049

JOB LOCATION

JOB #

WORK DONE AS DIRECTED

DATE	HOURS	EQUIPMENT	WORK DONE AS DIRECTED
<i>3-27-19</i>	<i>8</i>	<i>Case 5X8 78</i>	<i>M. D. L.</i>
		<i>18-049</i>	
		<i>205-03</i>	<i>3 hrs</i>
		<i>210-03</i>	<i>5 hrs</i>
			<i>H.E. 4111</i>

NOTICE: OUR OPERATORS WILL MAKE EVERY EFFORT TO PROTECT AND AVOID DAMAGE TO UNDERGROUND STRUCTURES. WE WILL ASSUME NO RESPONSIBILITY FOR DAMAGES UNLESS HAZARD IS EXPOSED AND DAMAGES NOTED ON THIS INVOICE. IT IS HEREBY AGREED THAT COSTS ARISING FOR COLLECTION OF AMOUNT DUE, SUCH AS ATTORNEY FEES, EXPENSES AND COURT COSTS WILL BE PAID BY CONTRACTOR. NO CLAIMS ALLOWED AFTER 10 DAYS FROM DATE OF INVOICE.

OPERATOR

J. D. Baker

BY

J. D. Baker



CCO No. 2, Item
No. 11

August 5, 2019

Willdan Engineering
13191 Crossroads Parkway North, Suite 405
Industry, CA 91746

Attn: Barry Knutson, Construction Manager

Re: 2017/18 Annual Street Overlay Project, City Project Number. 180804
Change Order Request 7.07 – Remove Concrete and AC as Directed at 15+65 Rialto Avenue

Dear Barry:

Matich Corporation respectfully submits this correspondence as a change order request to remove existing concrete and asphalt as directed at Station 15+65 on Rialto Avenue. Following layout sawcut and removal operations, Matich was directed to remove additional concrete and asphalt to make a driveway ADA compliant. The work was directed following the completion of removals and required re-mobilization to the area to perform. Please prepare a contract change order in the amount of \$1,323.67 for this work performed as directed.

Please do not hesitate to contact me with questions.

Respectfully,

Matich Corporation

A handwritten signature in black ink, appearing to read 'Jake Reade', is written over the company name.

by Jake Reade

Copy: File

Bcc:

Attachments:

DAILY EXTRA WORK REPORT

City Of Rialto Contractor Job: 18-049 - 2017/18 Annual Street Overlay Project Work Performed By: Match Corporation Description of Work: Remove Extra Concrete & AC To Make Driveway ADA Compliant On Rialto Ave At STA 15+65		Contract: 180804	Change Order: 100 Billing Number: 7.0 Report Date: 4/20/2019 Perform Date: 4/12/2019									
Labor Charges			Labor Charges									
Craft/Level	Employee Name	RT Hrs	OT Hrs	Subs Units	RT Rate	OT Rate	Subs Rate	Extended	RT Labor	691.04		
L01	LBR LG4	J Cinco	3.00		63.600			190.80	OT Labor	0.00		
L02	LBR LG3	E Martin	3.00		61.870			185.61	Subtotal Labor	691.04		
L03	LBR LG1	S Nunez	2.00		60.640			121.28	Subsistence	0.00		
L04	TMS TG5	R White	3.00		64.450			193.35	Other Expenses	0.00		
Equipment Charges									MU 20.00% 138.21	Labor Total 829.25		
Equipment ID	Class	Make	Model	A1	A2	RT Hrs	OT Hrs	RT Rate	OT Rate	Delay Factor	Extended	
E01	7271	TRUCK T&TT	12-20			3.00		38.380			115.14	
E02	3178	TRUON TRUN	3AXL			3.00		69.310			207.93	
Material/Specialist Work/Lump Sum or Unit Price Payment												
Number	Date	Vendor Name and Description					Units	Unit Price	Extended			
M01	72166517	4/12/2019 North American Recycling & Crushing, LLC / Dump Fees					1.000 LD	100.00000	100.00			
									Equipment Charges			
									Subtotal	323.07		
									MU 15.00%	48.46		
									Equipment Total	371.53		
									Material Charges			
									Subtotal	100.00		
									MU 15.00%	15.00		
									Material Total	115.00		
									Activity Total	1,315.78		
									Bill Surcharge			
									Bonding 0.60%	7.89		
									Work Total	1,323.67		
									Bill Subtotal	1,323.67		
For Owner/Resident Engineer's Use Only						Accepted:						
<input type="checkbox"/> New Bill		<input type="checkbox"/> Approved for Payment		Date of Action:		Customer:			Date:			
<input type="checkbox"/> Resubmittal		<input type="checkbox"/> Returned for Correction		Date Received:		Contractor: <i>[Signature]</i>			Date: 5/8/19			
									Bill Total +	1,323.67		



SHIP TO: MERRILL & LINDEN
 MERRILL & LINDEN / RIALTO
 FOB COLTON RECYCLE*
 FOB COLTON RECYCLE
 COLTON, CA

MATCH CORPORATION
 1596 HARRY SHEPPARD BLVD
 SAN BERNARDINO, CA 92408

CUSTOMER NO: 1928986-3750892

INVOICE NO: 72166517
 INVOICE DATE: 4/17/2019

72166517
 4/17/2019
 280-00
 618467
 APR 22 2019
 MATCH CORP

INVOICE AMT: 280-00
 ORDER: 618467
 DUE DATE: 5/15/2019

MATCH CORP

To ensure proper credit, please include remittance or list invoice numbers on your check remittance and send to:
 North American Crushing and Recycling
 P.O. Box 743662
 Los Angeles, CA 90074-3662
 714-777-6400 or help@NAREcycle.com

INVOICE

PLEASE DETACH AND RETURN WITH REMITTANCE

TAX EXEMPT I.D.:

SALES REP	LOCATION	PO NUMBER	REF	CONTRACT NO.				
15001 Aaron Waddell	COLTON RECYCLE	91346A/JOB#18-049						
INVOICE #	INVOICE DATE	CUSTOMER NUMBER	LOCATION	ORDER	BILL OF LADING	FOR		
72166517	4/17/2019	1928986-3750892	4936-171	618467		PICKUP		
SHIP DATE	TICKET	VEHICLE	PROD. CODE	DESCRIPTION	UOM	QUANTITY	PRICE	AMOUNT
4/17/2019	34404104	44E2	8LMB1	TY DUMP FEES - MIXED	Load	1.00	140-00	140-00
4/17/2019	34404127	44E2	8LMB1	TY DUMP FEES - MIXED	Load	1.00	140-00	140-00
						2.00*	100-	280-00
								200-
Total Quantity						2.00		
if Freight								
Taxes:						Percent	Amt	Sales Tax
								* \$200-
TERMS: NET 15th PROX - Payable in full by the 15th of each month following month of shipment.						Total Invoice		\$ 280.00
Invoices not paid according to our credit terms will be assessed a Finance Charge. Customer shall pay full cost of collection including but not limited to a reasonable attorney's fee for services rendered by suit or otherwise in collecting past due invoices								

* PER ATTACHED QUOTE
 POSTED
 18049
 305-2 | 700-2
 100- | 100-
 H.L. 4/23

Danger
Read important health information on reverse.
Peligro
Léase la información importante para la salud en el reverso.

RECEIVED BY:		CUSTOMER/CONSIGNEE:	
DRIVER	TIME:	PLANT:	TICKET NO:
4/12/2019	8:38AM	4936-171 COLTON-RECYC	34404127

WEIGHMASTER CERTIFICATE: THIS IS TO CERTIFY that the following described commodity was weighed, measured, or counted by a weighmaster, whose signature is on the certificate, who is a recognized authority of accuracy, as prescribed by Chapter 7 (commencing with Section 12700) of Division 5 of the California Business and Professions Code, administered by the Division of Measurement Standards of the California Department of Food and Agriculture.

WEIGHMASTER DEPUTY MICHAEL ANDRADA
LIMITED WARRANTY AND WARRANTY DISCLAIMER: Seller warrants for a period of one (1) year from date of delivery only that the material sold hereunder substantially complies with Seller's specification for said material or the specifications set forth in Seller's quotation. **SELLER HEREBY EXCLUDES ALL WARRANTIES OF MERCHANTABILITY AND FITNESS FOR ANY PURPOSE, AND ALL OTHER WARRANTIES, EXPRESS OR IMPLIED, OF THE MATERIAL SOLD HEREUNDER, OTHER THAN THE EXPRESS WARRANTY STATED ABOVE.** In addition, except to the extent otherwise set forth in the specification described above, Seller makes no warranty whatsoever with respect to specific gravity, absorption, whether the material is innocuous, non-deteriorous, or non-reactive, or whether the material is in conformance with any plans, other specifications, regulations, ordinances, statutes, or other standards applicable to customer's job or to said material as used by customer. **SELLER SHALL IN NO EVENT BE RESPONSIBLE FOR ANY INCIDENTAL OR CONSEQUENTIAL DAMAGE CAUSED BY NON-COMPLIANCE OF THE MATERIAL WITH SPECIFICATION, OR FOR ANY DEFECTS IN THE MATERIALS SOLD HEREUNDER.**

ALL SALES AND DELIVERS MADE SUBJECT TO SELLER'S GENERAL TERMS AND CONDITIONS.
AS EVIDENCED BY SIGNATURE OR DEPARTURE FROM SELLER'S FACILITY, CARRIER ACKNOWLEDGES THAT CARRIER IS SOLELY RESPONSIBLE FOR THE ACCURACY OF THIS VEHICLE'S TARE WEIGHT, AXLE WEIGHTS AND GROSS WEIGHT. CARRIER SHALL BE RESPONSIBLE FOR NOTIFYING SELLER WHEN ANY TRUCK OR TRAILER HAS BEEN OVERLOADED SO AS TO RENDER IT OUT OF COMPLIANCE WITH ANY APPLICABLE WEIGHT LIMITS. TO THE MAXIMUM EXTENT ALLOWED BY LAW, CARRIER SHALL INDEMNIFY SELLER FOR ANY LOSS CAUSED BY OVERLOADING.

TRUCK TARE AND GROSS WEIGHTS ARE DETERMINED WITH THE DRIVER IN THE VEHICLE.

CUSTOMER: 3750892 OK#		CUSTOMER PURCHASE ORDER: 91346AJOB#18-049		GOVT CONTRACT:	
ORDER: 618467 FOB COLTON RECYCLE* FOB COLTON RECYCLE			PICKED UP		
DESTINATION: MERRILL & LINDEN RIALTO			ZONE/MILES		
PRODUCT: 8LMB1 TW DUMP FEES - MIXED					
COMMENTS:					
TRUCK 44E2 TW		CARRIER W089		CUSTOMER PICKED UP	
LICENSE 28044E2 CUST-UNCL		TRAILER ID NO		TRAILER ID NO	
FREIGHT TYPE A		AXLES 0		TARE DATE 12/30/1899 TARE EXPIRE 01/07/1900	
GROSS LBS	TARE LBS	NET LBS	LOADS	LOADS TODAY	LOADS TODAY
0	0	0	1.00	2.00	0
GROSS KG	TARE KG	NET KG	IN PLANT		OUT OF PLANT
0	0	0	12:00 am		8:38AM
THIS SECTION FOR CASH SALES ONLY					
CASH SALE PER TON	MATERIAL	HAUL	TAX	OTHER CHARGES	COD TOTAL
TOTAL	MATERIAL	HAUL	TAX	OTHER CHARGES	COD TOTAL
FREIGHT TIME REPORT	ARRIVE JOB	START UNLOAD	FINISH UNLOAD	JOB TIME	DELAY TIME

We make deliveries inside the curb line at the customer's risk only and accept no responsibility whatsoever for damage resulting from such deliveries.

Danger
Read important health information on reverse.
Peligro
Léase la información importante para la salud en el reverso.

RECEIVED BY:		CUSTOMER/CONSIGNEE:	
DRIVER	TIME:	PLANT:	TICKET NO:
4/12/2019	8:38AM	4936-171 COLTON-RECYC	34404127

WEIGHMASTER CERTIFICATE: THIS IS TO CERTIFY that the following described commodity was weighed, measured, or counted by a weighmaster, whose signature is on the certificate, who is a recognized authority of accuracy, as prescribed by Chapter 7 (commencing with Section 12700) of Division 5 of the California Business and Professions Code, administered by the Division of Measurement Standards of the California Department of Food and Agriculture.

WEIGHMASTER DEPUTY MICHAEL ANDRADA
LIMITED WARRANTY AND WARRANTY DISCLAIMER: Seller warrants for a period of one (1) year from date of delivery only that the material sold hereunder substantially complies with Seller's specification for said material or the specifications set forth in Seller's quotation. **SELLER HEREBY EXCLUDES ALL WARRANTIES OF MERCHANTABILITY AND FITNESS FOR ANY PURPOSE, AND ALL OTHER WARRANTIES, EXPRESS OR IMPLIED, OF THE MATERIAL SOLD HEREUNDER, OTHER THAN THE EXPRESS WARRANTY STATED ABOVE.** In addition, except to the extent otherwise set forth in the specification described above, Seller makes no warranty whatsoever with respect to specific gravity, absorption, whether the material is innocuous, non-deteriorous, or non-reactive, or whether the material is in conformance with any plans, other specifications, regulations, ordinances, statutes, or other standards applicable to customer's job or to said material as used by customer. **SELLER SHALL IN NO EVENT BE RESPONSIBLE FOR ANY INCIDENTAL OR CONSEQUENTIAL DAMAGE CAUSED BY NON-COMPLIANCE OF THE MATERIAL WITH SPECIFICATION, OR FOR ANY DEFECTS IN THE MATERIALS SOLD HEREUNDER.**

ALL SALES AND DELIVERS MADE SUBJECT TO SELLER'S GENERAL TERMS AND CONDITIONS.
AS EVIDENCED BY SIGNATURE OR DEPARTURE FROM SELLER'S FACILITY, CARRIER ACKNOWLEDGES THAT CARRIER IS SOLELY RESPONSIBLE FOR THE ACCURACY OF THIS VEHICLE'S TARE WEIGHT, AXLE WEIGHTS AND GROSS WEIGHT. CARRIER SHALL BE RESPONSIBLE FOR NOTIFYING SELLER WHEN ANY TRUCK OR TRAILER HAS BEEN OVERLOADED SO AS TO RENDER IT OUT OF COMPLIANCE WITH ANY APPLICABLE WEIGHT LIMITS. TO THE MAXIMUM EXTENT ALLOWED BY LAW, CARRIER SHALL INDEMNIFY SELLER FOR ANY LOSS CAUSED BY OVERLOADING.

TRUCK TARE AND GROSS WEIGHTS ARE DETERMINED WITH THE DRIVER IN THE VEHICLE.

CUSTOMER: 3750892 OK#		CUSTOMER PURCHASE ORDER: 91346AJOB#18-049		GOVT CONTRACT:	
ORDER: 618467 FOB COLTON RECYCLE* FOB COLTON RECYCLE			PICKED UP		
DESTINATION: MERRILL & LINDEN RIALTO			ZONE/MILES		
PRODUCT: 8LMB1 TW DUMP FEES - MIXED					
COMMENTS:					
TRUCK 44E2 TW		CARRIER W089		CUSTOMER PICKED UP	
LICENSE 28044E2 CUST-UNCL		TRAILER ID NO		TRAILER ID NO	
FREIGHT TYPE A		AXLES 0		TARE DATE 12/30/1899 TARE EXPIRE 01/07/1900	
GROSS LBS	TARE LBS	NET LBS	LOADS	LOADS TODAY	LOADS TODAY
0	0	0	1.00	2.00	0
GROSS KG	TARE KG	NET KG	IN PLANT		OUT OF PLANT
0	0	0	12:00 am		8:38AM
THIS SECTION FOR CASH SALES ONLY					
CASH SALE PER TON	MATERIAL	HAUL	TAX	OTHER CHARGES	COD TOTAL
TOTAL	MATERIAL	HAUL	TAX	OTHER CHARGES	COD TOTAL
FREIGHT TIME REPORT	ARRIVE JOB	START UNLOAD	FINISH UNLOAD	JOB TIME	DELAY TIME

We make deliveries inside the curb line at the customer's risk only and accept no responsibility whatsoever for damage resulting from such deliveries.



CCO No. 2, Item
No. 12

August 5, 2019

Willdan Engineering
13191 Crossroads Parkway North, Suite 405
Industry, CA 91746

Attn: Barry Knutson, Construction Manager

Re: 2017/18 Annual Street Overlay Project, City Project Number. 180804
Change Order Request 7.08 – Repair Shallow Water Service

Dear Barry:

Matich Corporation respectfully submits this correspondence as a change order request to repair a broken water service to the Clutch Masters business on Valley Boulevard as directed by the City. During removal of the existing concrete driveway, the water service started leaking water. The service was installed improperly at a very shallow depth, which was damaged as the concrete was removed from the driveway. The City's contracted water service operator refused to repair the shallow line and Matich was directed to repair it. Please prepare a contract change order in the amount of \$2,268.94 for this work performed as directed.

Please do not hesitate to contact me with questions.

Respectfully,

Matich Corporation

A handwritten signature in black ink, appearing to read 'J. Reade', is written over the company name.

by Jake Reade

Copy: File
Bcc:
Attachments:

DAILY EXTRA WORK REPORT

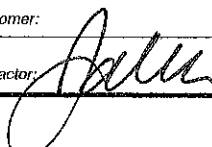
City Of Rialto Contractor Job: 18-049 - 2017/18 Annual Street Overlay Project Work Performed By: Match Corporation Description of Work: Repair Shallow Water Service		Contract: 180804	Change Order 100 Billing Number 8.0 Report Date 4/20/2019 Perform Date 4/17/2019								
Labor Charges			Labor Charges								
Craft/Level	Employee Name	RT Hrs	OT Hrs	Subs Units	RT Rate	OT Rate	Subs Rate	Extended			
L01 OE OF10	RF Del Toro	2.00			84.030			168.06	RT Labor 168.06		
Equipment Charges			Equipment Charges								
Equipment ID	Class	Make	Model	A1	A2	RT Hrs	OT Hrs	RT Rate	OT Rate	Delay Factor	Extended
E01 7255	TRUCK	T&TT	06-12			2.00		29.600			59.20
Material/Specialist Work/Lump Sum or Unit Price Payment											
Number	Date	Vendor Name and Description					Units	Unit Price	Extended		
M01	4/17/2019	SRD Engineering, Inc. / 3/4" Waterline Repair					1.000 LS	1,726.66000	1,726.66		
									OT Labor 0.00 Subtotal Labor 168.06 Subsistence 0.00 Other Expenses 0.00 MU 20.00% <u>33.61</u> Labor Total 201.67		
									Equipment Charges Subtotal 59.20 MU 15.00% <u>8.88</u> Equipment Total 68.08		
									Material Charges Subtotal 1,726.66 MU 15.00% <u>259.00</u> Material Total 1,985.66		
									Activity Total 2,255.41		
									Bill Surcharge Bonding 0.60% 13.53		
									Work Total 2,268.94		
									Bill Subtotal 2,268.94		
For Owner/Resident Engineer's Use Only						Accepted:					
<input type="checkbox"/> New Bill	<input type="checkbox"/> Approved for Payment	Date of Action:		Customer:		Date:					
<input type="checkbox"/> Resubmittal	<input type="checkbox"/> Returned for Correction	Date Received:		Contractor: 		Date: 5/8/19					
									Bill Total + 2,268.94		

INVOICE

Invoice #: **6040670**

Please pay from this invoice.

Commercial Account:



SRD ENGINEERING INC
3578 E ENTERPRISE DRIVE

Account **XXXX XXXX XXXX 0368**
Amount Due **\$151.66**
Transaction Date **04/17/19**
Payment Due Date **07/12/19**

Customer #	Purchased By	Authorized By	Purchase Order/Job Name	Customer Agreement #
00009	RIVAS JOSE	RIVAS JOSE	HD4588	
Store / Register #: 6683, RIALTO, CA / 4				

PRODUCT	SKU #	QUANTITY	UNIT	UNIT PRICE	TOTAL PRICE
1X6GALNIPLE	00001827880000100048	1.0000	EA	\$4.34	\$4.34
3/4X6GALNIPL	000018268800000100048	1.0000	EA	\$3.40	\$3.40
3/4 GAL CPLG	00001818700000100007	1.0000	EA	\$2.94	\$2.94
3/4 GAL CPLG	00001818700000100007	1.0000	EA	\$2.94	\$2.94
3/4 GAL CPLG	00001818700000100007	1.0000	EA	\$2.94	\$2.94
3/4 GAL UNION	00001821920000100007	1.0000	EA	\$10.78	\$10.78
3/4 GAL UNION	00001821920000100007	1.0000	EA	\$10.78	\$10.78
3/4 GAL CPLG	00001818700000100007	1.0000	EA	\$2.94	\$2.94
3/4X6GALNIPL	000018268800000100048	1.0000	EA	\$3.40	\$3.40
1X3/4 GALCPL	00001822810000100007	1.0000	EA	\$4.12	\$4.12
1IN GAL CPLG	00001818890000100007	1.0000	EA	\$3.75	\$3.75
1X3/4 GALCPL	00001822810000100007	1.0000	EA	\$4.12	\$4.12
8OZ THRD SEALANT NO. 5	00006769200000100021	1.0000	EA	\$11.29	\$11.29
1X10GALNIPPL	00001828180000100048	1.0000	EA	\$6.98	\$6.98
BUSHING	00002568000000100009	1.0000	EA	\$3.34	\$3.34
BUSHING	00002568000000100009	1.0000	EA	\$3.34	\$3.34
1/2"X260" PTFE THRD SEAL TAPE SPK	00002421240000100021	1.0000	EA	\$4.73	\$4.73

continued ⇨

Questions About Your Account **ACCT MGR** JESSICA HAMM EXT 4676609 **PHONE** 1-800-494-1946
EMAIL JESSICA.LEIGH.HAMM@CITI.COM **FAX** 1-877-969-6282

NOTICE: SEE REVERSE SIDE FOR IMPORTANT INFORMATION Page 1 of 4 8 HP 17 This Account is Issued by Citibank, N.A.

Please detach and return lower portion with your payment to insure proper credit. Retain upper portion for your records. ⇩
 Your Account Number is xxxxx xxxxx xxxxx 0368

P.O. Box 790420
 St. Louis, MO 63179



Invoice Enclosed

Amount Due **\$151.66**
Due Date **July 12, 2019**
Invoice Number **6040670**



Print address changes on the reverse side.
 Make Checks Payable to ▼

SRD ENGINEERING INC
 3578 E ENTERPRISE DRIVE
 ANAHEIM, CA 92807-1627

HOME DEPOT CREDIT SERVICES
 DEPT. xx - xxxxxx0368
 PO BOX 78047
 PHOENIX, AZ 85062-8047

Other Account and Payment Information

WHEN YOUR PAYMENT WILL BE CREDITED: For payments by regular mail, please allow 5-7 days for your payment to reach us. Payment must be received in proper form at our processing facility by 5 p.m. local time there to be credited as of that day. All payments received at the processing facility in proper form after that hour will be credited as of the following day. There may be a delay of up to 5 days in crediting a payment sent by mail if it is not in the proper form or is addressed to a location other than the address listed on the return envelope or on the front of the payment coupon, or for courier or express mail payments, to the Express Mail address set forth in the Express Mail section.

PROPER FORM for payments sent by mail or courier.

For a payment to be in proper form, you should:

- **ENCLOSE** your check or money order. No cash, gift cards, or foreign currency please.

- **INCLUDE** the last four digits of your account number and name.

COPY FEE. We charge \$5 for each copy of a billing statement that dates back 3 months or more. We add the fee to a balance of our choosing. We reserve the right to add this fee to balances subject to a higher annual percentage rate. We waive the fee if your request for the copy relates to a billing error or disputed purchase.

PAYMENT OTHER THAN BY MAIL:

- **Online Payments.** Go to the URL on Page 1 of your statement to make a payment. For security reasons, you may not be able to pay your entire New Balance the first time you make a payment online. The payment cutoff time for Online Bill Payments is 5 p.m. Eastern time. Payments received after 5 p.m. Eastern time will be credited as of the next day.

- **Phone.** Call the phone number on Page 1 of your statement to make a payment. We may process your payment electronically after we verify your identity. There is no fee for this service. The payment cutoff time for Phone Payments is 5 p.m. Eastern time. Payments received after 5 p.m. Eastern time will be credited as of the next day.

- **Express Payments.** Send payment by courier or express mail to: Attn: Prox Payment Dept, 6716 Grade Lane, Building 9, Suite 910, Louisville, KY, 40213. Payment must be received in proper form, at the proper address, by 5 p.m. Eastern time in order to be credited as of that day. All payments received in proper form, at the proper address, after 5 p.m. Eastern time will be credited as of the next day.

- **In-Store Payments.** For your added convenience, payments can be made at The Home Depot® stores, with no service fee. Any payment in proper form accepted in-store will be credited as of that day. However, credit availability may be subject to verification of funds.

If you send an eligible check with this payment coupon you authorize us to complete your payment by electronic debit. If we do the checking account will be debited in the amount on the check. We may do this as soon as the day we receive the check. Also the check will be destroyed.

REPORT A LOST, STOLEN OR NEVER RECEIVED CARD IMMEDIATELY: Customer Service is available 24 hours a day, 7 days a week.

CUSTOMER SERVICE WRITTEN INQUIRY ADDRESS:

Home Depot Credit Services, P.O. Box 790340, St. Louis, MO 63179

T10697 - HP - 1420 - 0PRX - 0000 - - - - - X -

THD PROX EN JUN16

Change of Address

Please print address changes in blue or black ink

PRO EXPANDED ASSORTMENT FOR PROS

Get thousands of maintenance and repair products now - including special orders!



SAVE MORE EVERY DAY WHEN YOU BUY IN BULK

- 4000+ bulk eligible products
- Get lower prices on job or project materials with minimum purchase

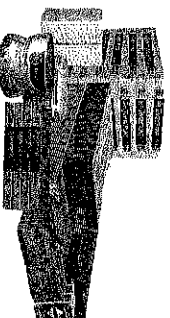

PRO

INVOICE

Invoice #:

6040670 cont.



Commercial Account



Remit payment and make checks payable to:
HOME DEPOT CREDIT SERVICES
DEPT. xx - xxxxx0368
PO BOX 78047
PHOENIX, AZ 85062-8047

Account

xxxx xxxx xxxx 0368

Transaction Date

04/17/19

Payment Due Date

07/12/19

PRODUCT	SKU #	QUANTITY	UNIT	UNIT PRICE	TOTAL PRICE
1" FP BALL VALVE FPT 600PSI LF	00008700000000100018	1.0000	EA	\$20.65	\$20.65
3/4" FP BALL VALVE FPT 600PSI LF	00008686370000100018	1.0000	EA	\$15.30	\$15.30
3/4X36GAPIPE	00003497980000100048	1.0000	EA	\$18.67	\$18.67

SUBTOTAL	\$140.75
TAX	\$10.91
SHIPPING	\$0.00
TOTAL	\$151.66

Please pay from this invoice.



CCO No. 2, ITEM
No. 13

August 5, 2019

Willdan Engineering
13191 Crossroads Parkway North, Suite 405
Industry, CA 91746

Attn: Barry Knutson, Construction Manager

Re: 2017/18 Annual Street Overlay Project, City Project Number. 180804
Change Order Request 7.09 – Sawcut Extra Driveway for Removal and Replacement on Valley Blvd

Dear Barry:

Matich Corporation respectfully submits this correspondence as a change order request to sawcut an added driveway for removal on Valley Boulevard at the P&S Truck Center as directed. Following completion of layout and sawcut operations, Matich was directed to sawcut an extra driveway for removal. The sawcut subcontractor re-mobilized to the jobsite to perform this work. Please prepare a contract change order in the amount of \$485.90 for this work performed as directed.

Please do not hesitate to contact me with questions.

Respectfully,

Matich Corporation

A handwritten signature in black ink, appearing to read 'J. Reade', is written over the printed name 'Matich Corporation'.

by Jake Reade

Copy: File

Bcc:

Attachments:

DAILY EXTRA WORK REPORT

City Of Rialto	Contract: 180804	Change Order 100
Contractor Job: 18-049 - 2017/18 Annual Street Overlay Project		Billing Number 9.0
Work Performed By: Matich Corporation		Report Date 4/20/2019
Description of Work: Sawcut Extra Driveway For Removal On Valley Blvd At P & S Truck Center		Perform Date 4/19/2019

Material/Specialist Work/Lump Sum or Unit Price Payment						
Number	Date	Vendor Name and Description	Units	Unit Price	Extended	
M01 20193228	4/19/2019	Spartan Concrete & Asphalt Cutting, Inc. / Flatsaw	1.000 LS	420.00000	420.00	

Labor Charges
Equipment Charges
Material Charges
Subtotal 420.00
MU 15.00% <u>63.00</u>
Material Total 483.00
Activity Total 483.00
Bill Surcharge
Bonding 0.60% 2.90
Work Total 485.90
Bill Subtotal 485.90

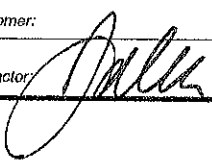
<p style="text-align: center;">For Owner/Resident Engineer's Use Only</p> <p> <input type="checkbox"/> New Bill <input type="checkbox"/> Approved for Payment Date of Action: _____ <input type="checkbox"/> Resubmittal <input type="checkbox"/> Returned for Correction Date Received: _____ </p>	<p>Accepted:</p> <p>Customer: _____ Date: _____</p> <p>Contractor:  Date: 5/8/19</p>	<p>Bill Total + 485.90</p>
---	--	--

Spartan Concrete & Asphalt Cutting, Inc.

Invoice

20193228

Flat Sawing - Wall Sawing - Coring - Demolition - Skidsteers - GPR Scanning

Mailing Address:

P.O. Box 1763, Palm Springs, CA 92263-1763
760-251-8095

Date of Service: 4/19/2019

Cont. Lic. # 683437 FIN # 33-0958643
Laborsers Union Local 1184 DIR Contr. Reg.# 1000011594

P.O. / Job#: 18-049

Customer:

MATCH CORPORATION
P.O. BOX 10
HIGHLAND, CA 92346

Jobsite: RIVERSIDE X VALLEY
RIALTO

gkleespies@matchcorp.com

Customer is responsible for ensuring Spartan is provided with all Public Works information.

APR 22 2019

Description Of Work Completed	Charge
1 - FLATSAW 52 LF X 4 IN THICK ASPHALT	
2 - FLATSAW 10 LF X 4 IN THICK CONCRETE SIDEWALK	
3 - RESIDUE CLEANUP / WASHOUT ONSITE	
CHARGE OPERATOR: STEPHEN BURROW MIN 2.0 HR @ \$ 140.00 PER HR ONSITE TIME: 1.0 HR	280.00
CHARGE MOBILIZATION: (1) @ \$ 140.00	140.00
Terms: Due on receipt	TOTAL AMOUNT DUE:
Invoices not paid within terms of agreement are subject to a finance charge of 2.0% per month. In the event of default, customer shall be responsible to pay all necessary and reasonable collection costs and expenses incurred, including attorney's fees.	\$420.00

POSTED

Operator: SB

PLEASE NOTE INVOICE NUMBER ON PAYMENT CHECK/STUB.
We accept eCHECKS / MASTERCARD / VISA / AMERICAN EXPRESS
JOINT CHECKS ACCEPTED WITH ACCOMPANYING SIGNATURE GUARANTEE ONLY.

Please add accounting@spartanconcretecutting.com AND admin@spartanconcretecutting.com to your contacts
to receive your invoices and statements
Thank you!

Spartan Concrete & Asphalt Cutting, Inc.

Field Invoice

Mailing: P.O. Box 1763, Palm Springs, CA 92263-1763

760-251-8095

CA LIC #683437 FIN #33-0958643

PWCR# 1000011594

CUSTOMER:

101-14

Service Date: 4-19-19 FRS

MATICH 18-049
extra work
on Valley Ct

Operator: STEVE

Laborer: _____

Apprentice: _____

CONTACT/PHONE#:

Pand S truck
Center

JOB SITE:

RIVERSIDE X VALLEY
RINALCO

PO/ JOB#:

18-049

ONE ITEM PER LINE	DESCRIPTION OF WORK PERFORMED
	FINISH 52' 4" A/C
	10' 4" c/c SIDEWALK
	Ladder ___ Lft ___ W/D Vac
	Ladder ___ Lft ___ W/D Vac
	Ladder ___ Lft ___ W/D Vac
	Ladder ___ Lft ___ W/D Vac
	Ladder ___ Lft ___ W/D Vac

Washout On Site: YES NO # Barrels hauled offsite (charge of \$ 70.00 per barrel)
 Water on Site: YES NO
 Site Preparation Visqueen Paper Chipping
 All Charges On Field Invoice Are Estimates Only
 And Subject To Final Approval

We accept
 CHECKS / CHECK / MASTERCARD / VISA / AE
 JOBSITE PAYMENT- \$

General Terms and Conditions:
 1 - It is the responsibility of the contractor/homeowner to layout the job and locate and/or deactivate all pipes, lines, utilities, and potential hazardous systems within work area. Said contractor/homeowner agrees to be completely responsible for any injury or damage to person(s) or property(s), including but not limited to damage to underground utilities caused by or arising from homeowner/contractor's failure to or accurately locate such facilities.
 2 - Spartan Concrete & Asphalt Cutting, Inc is not responsible for damage to underground lines, structures, utilities, floors or the contents of the floors below.

Customer Signature: *[Signature]*
 I acknowledge that I have read and agree to the above mentioned General Terms and Conditions.

Customer Initials: _____ APPROVAL -NO SLURRY CLEANUP

SPARTAN WILL BE SENDING YOUR INVOICE BY EMAIL
 PLEASE ADD: accounting@spartanconcretecutting.com and
admin@spartanconcretecutting.com TO YOUR CONTACTS

Arrival Time: 12:30 and PM
 Lunch OUT: -- IN: --
 Depart Time: 1:30 and PM
 Standby Time:
 TOTAL ON-SITE HOURS: 1 hr.



CCO No. 2, Item
No. 14

August 5, 2019

Willdan Engineering
13191 Crossroads Parkway North, Suite 405
Industry, CA 91746

Attn: Barry Knutson, Construction Manager

Re: 2017/18 Annual Street Overlay Project, City Project Number. 180804
Change Order Request 7.10 – Remove New Ramp on Linden Avenue and Replace as Directed

Dear Barry:

Matich Corporation respectfully submits this correspondence as a change order request to remove a portion of a new concrete ramp, curb and sidewalk originally constructed as directed by the City and re-construct based on a new design provided by the City. The new design accommodated both the compliance issue at the ramp and access to the apartment building on the southwest corner of Linden and Foothill. Please prepare a contract change order in the amount of \$4,631.44 for this work performed as directed.

Please do not hesitate to contact me with questions.

Respectfully,

Matich Corporation

A handwritten signature in black ink, appearing to read 'Jake Reade', is written over the company name.

by Jake Reade

Copy: File

Bcc:

Attachments:

DAILY EXTRA WORK REPORT

City Of Rialto Contractor Job: 18-049 - 2017/18 Annual Street Overlay Project Work Performed By: Matich Corporation Description of Work: Remove Part Of ADA Ramp On Linden Ave	Contract: 180804	Change Order 100 Billing Number 10.0 Report Date 4/28/2019 Perform Date 4/25/2019
--	-------------------------	--

Material/Specialist Work/Lump Sum or Unit Price Payment			
Number	Date	Vendor Name and Description	Extended
M01 36709	4/25/2019	Hixson Backhoe Service Inc / 580 Backhoe	2.000 HR 155.00000 310.00
M02 1618959	4/25/2019	A.C. Byers Trucking Inc. / Super Ten Wheeler	2.000 HR 90.00000 180.00

Labor Charges
Equipment Charges
Material Charges
Subtotal 490.00
MU 15.00% 73.50
Material Total 563.50
Activity Total 563.50
Bill Surcharge
Bonding 0.60% 3.38
Work Total 566.88
Bill Subtotal 566.88

For Owner/Resident Engineer's Use Only <input type="checkbox"/> New Bill <input type="checkbox"/> Approved for Payment <input type="checkbox"/> Resubmittal <input type="checkbox"/> Returned for Correction Date of Action: _____ Date Received: _____	Accepted: Customer: _____ Date: _____ Contractor:  Date: 5/8/19
--	---

Bill Total + **566.88**

EXTRA WORK REPORT

JOB NUMBER 18-049
 DATE PERFORMED 4/25/19
 DATE OF REPORT 4/28/19

CHANGE ORDER NUMBER _____

WORK PERFORMED BY Matich Corp

DESCRIPTION OF WORK remove part of ADA ramp on Linden.

EQUIPMENT

EQP. NO.	MAKE	MODEL	HOURS	RATE	AMOUNT
SUBTOTAL					
MARK-UP					
TOTAL (A)					

LABOR

CRAFT	INT	NAME		REG	HOURS		RATE	EXTENDED TOTAL
		LAST	FIRST		RATE	OT		
SUBTOTAL								
LBR BURDEN								
SUBSISTENCE								
LBR MARK-UP								
TOTAL (B)								

MATERIAL and/or WORK done by specialists or LUMP SUM or UNIT PRICE PAYMENTS:

VENDOR	INVOICE NO.	DATE	DESCRIPTION	UNITS	UNIT COST OR NET PAY	EXTENDED TOTAL
Hixson Backhoe			580 backhoe	2 hrs		
A.C. Byers			Super ten wheeler	2 hrs		
SUBTOTAL						
MARK-UP						
TOTAL (A)						

WORK AUTHORIZED BY: [Signature]
 OWNER'S REPRESENTATIVE

[Signature]
 MATICH'S REPRESENTATIVE

OFFICE USE ONLY

TOTAL (A + B + C)

HIXSON BACKHOE SERVICE INC

PO BOX 715
MURRIETA, CA 92564-0715
(951) 677-6212 * FAX (951) 677-3894
CSLB #956710 * SB(Micro)

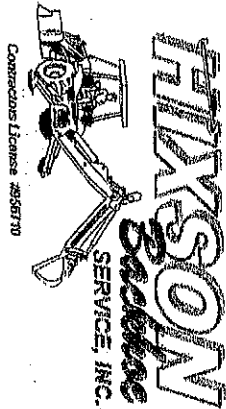

INVOICE

DATE	INVOICE NO.
4/27/2019	29306

BILL TO
 Match Corporation
 P.O. Box 10
 Highland, CA 92346

JOB LOCATION
 Yucca Ave & Merrill
 Rialto, CA
 Dir #267433

RECEIVED
 MAY 06 2019
MATCH CORP.

BILL TO	Match Corporation P.O. Box 10 Highland, CA 92346
----------------	--

JOB LOCATION	Yucca Ave & Merrill Rialto, CA Dir #267433
---------------------	--

P.O. NO.	TERMS	JOB #
	30 days	18-049

DATE	DESCRIPTION	TICKET #	HOURS	RATE	AMOUNT
4/22/2019	580 Backhoe W/Operator	36706	8	155.00	1,240.00
4/23/2019	580 Backhoe W/Operator	36707	8	155.00	1,240.00
4/24/2019	580 Backhoe W/Operator	36708	8	155.00	1,240.00
4/25/2019	580 Backhoe W/Operator	36709	8	155.00	1,240.00
4/26/2019	580 Backhoe W/Operator	36710	8	155.00	1,240.00
4/22/2019	580 Backhoe W/Operator	37414	6	155.00	930.00
4/23/2019	580 Backhoe W/Operator	37405	7	155.00	1,085.00
4/23/2019	580 Backhoe W/Atlas Breaker	37405	1	207.00	207.00
4/24/2019	580 Backhoe W/Operator	37406	8	155.00	1,240.00
4/25/2019	580 Backhoe W/Operator	37407	7	155.00	1,085.00
4/26/2019	580 Backhoe W/Operator	37408	8	155.00	1,240.00
	<u>18049</u>				
	406-3: \$1,550-				
	505-3: \$1,240-				
	506-1: \$2,007-				
	506-3: \$1,800-				
	601-4: \$465-				
	602-2: \$2,325-				
	602-3: \$930-				
	700-4: \$1,240-				
	700-5: \$310-				

Certified Payroll - Submitted on LCP TRACKER & CA DIR eCPR - **Total \$11,987.00**
 Thank You

NO 36709

HIXSON BACKHOE SERVICE, INC.
P.O. Box 0715, Murietta, CA 92564-0715 • (951) 677-6212 • FAX (951) 677-3894

WORK FOR

P.O.#

JOB LOCATION

JOB #

WATKIN
LIVATO

18-0119

WORK DONE AS DIRECTED

DATE	HOURS	EQUIPMENT	WORK DONE AS DIRECTED
4-25-19	8	580 #1	18-049
			506-3
			Linden E/w 2 hrs (700-5)

NOTICE: OUR OPERATORS WILL MAKE EVERY EFFORT TO PROTECT AND AVOID DAMAGE TO UNDERGROUND STRUCTURES. WE WILL ASSUME NO RESPONSIBILITY FOR DAMAGES UNLESS HAZARD IS EXPOSED AND DAMAGES NOTED ON THIS INVOICE. IT IS HEREBY AGREED THAT COSTS ARISING FOR COLLECTION OF AMOUNT DUE, SUCH AS ATTORNEY FEES, EXPENSES AND COURT COSTS WILL BE PAID BY CONTRACTOR. NO CLAIMS ALLOWED AFTER 10 DAYS FROM DATE OF INVOICE.

OPERATOR

BY

[Signature] *[Signature]*

A. C. BYERS TRUCKING INC.

210 S. "G" STREET
SAN BERNARDINO CA 92410-3309
Office: 909-884-6064 Fax: 909-884-5024
CA #017617

Date: 05/06/19
Invoice: 201905-77
Job: 04/01/19-74

Customer Job: 18-049

Origin:

MATCH CORPORATION
P.O. BOX 10
HIGHLAND CA 92346

Destination:

Date	Truck	Ft Bill	Description	Qty	Rate	Amount
04/25	1361	3055858		6.00	90.00	540.00
04/25	1584	4016752		6.00	90.00	540.00
04/25	1602	1618959		6.50	90.00	585.00
04/26	1602	1618960		7.80	90.00	702.00
04/26	461A	4359180		6.00	90.00	540.00

TOTAL: 49,536.00

** Thank You ***

**NON-NEGOTIABLE BILL OF LADING
AND TRANSPORTATION AGREEMENT**

BILL NO.

PRINCIPAL CARRIER A.C. Byers

DATE 4/25/19

A - 1618959

ADDRESS

CITY/STATE/ZIP

PH

JOB # 18-049

BROKER # B7602

TRUCK # K-101

TRAILER #

CA # 285215

UNDERLYING CARRIER (IF ANY) TRK WATERBURY TRANSB TRK

ADDRESS

PH

SHIPPER

WATSON F. OGDEN

RECEIVER

ADDRESS

ADDRESS

CITY/STATE/ZIP

CITY/STATE/ZIP

POINT OF ORIGIN

MSDALL 4 CORN - KINGS

POINT OF DESTINATION

- EQUIPMENT TYPE
- 10-WHEELER
 - SUPER-10
 - STRONG ARM

- SUPER TAG
- TRANSFER
- DBL BOTTOMS
- SEMI-BOTTOM

- END DUMP
- SIDE DUMP
- TRUCK & PUP
- WATER TRUCK

- FLAT BED
- MIXER
- OTHER

HOURLY TONNAGE PER LOAD
RATE @ \$ 90.00

TAG NO.	WEIGHT	COMMODITY	LOADING		UNLOADING		STANDBY TIME	BREAKDOWN OR REASON FOR DELAY
			ARRIVE	DEPART	ARRIVE	DEPART		
1	111	3 TRK						
2								
3								
4	1	1 TRK						
5								
6								
7	1	1 TRK						
8								
9								
10								
11								
12								
13								
14								
15								

STARTING TIME LAST TRIP	ENDING TIME LAST TRIP	TOTAL TIME LAST TRIP	DEDUCTIBLE TIME LAST TRIP	LOADING TIME LAST TRIP
<u>4:00</u>	<u>5:30</u>	<u>1:30</u>	<u>0</u>	<u>0</u>

NET TIME	TOTAL TONS	ACCESSORIAL OTHER	TOTAL CHARGES
<u>6:15</u>			

TRK by B7602
DRIVER SIGNATURE

Job # 18-049
SHIPPER/RECEIVER (AGENT OR DEBITOR) SIGNATURE

SUBJECT TO TERMS AND CONDITIONS ON REVERSE SIDE

DAILY EXTRA WORK REPORT

City Of Rialto	Contract: 180804	Change Order 100
Contractor Job: 18-049 - 2017/18 Annual Street Overlay Project		Billing Number 11.0
Work Performed By: Matich Corporation		Report Date 4/26/2019
Description of Work: Sawcut, Demo Curb, Re-Set Curb, Pour & Finish Ramp, 100 Sf Of Sidewalk Put In On Linden Ave		Perform Date 4/26/2019

Labor Charges								
Craft/Level	Employee Name	RT Hrs	OT Hrs	Subs Units	RT Rate	OT Rate	Subs Rate	Extended
L01 OE OF8	B Koleszar	6.00			83.340			500.04
L02 LBR LG4	A Ojeda	6.00			63.600			381.60
L03 LBR LG3	W Pelayo	6.00	1.50		61.870	80.650		492.20
L04 CMTMS LG5	J Perez	6.00			66.360			398.16
L05 CMTMS LG5	E Olvera	6.00			66.360			398.16
L06 CMTMS LG5	M Escamilla	6.00			66.360			398.16

Labor Charges	
RT Labor	2,447.34
OT Labor	120.98
Subtotal Labor	2,568.32
Subsistence	0.00
Other Expenses	0.00
MU 20.00%	513.66
Labor Total	3,081.98

Equipment Charges											
Equipment ID	Class	Make	Model	A1	A2	RT Hrs	OT Hrs	RT Rate	OT Rate	Delay Factor	Extended
E01 7273	TRUCK	T&TT	12-20			6.00		38.380			230.28

Equipment Charges	
Subtotal	230.28
MU 15.00%	34.54
Equipment Total	264.82

Material/Specialist Work/Lump Sum or Unit Price Payment						
Number	Date	Vendor Name and Description	Units	Unit Price	Extended	
M01 38283	4/26/2019	Matich Corporation / Big Tex Utility Trailer	6.000 EA	10.00000	60.00	
M02 108019	4/26/2019	Rancho Ready Mix Products, L.P. / 520-C-2500	1.000 LS	543.06000	543.06	

Material Charges	
Subtotal	603.06
MU 15.00%	90.46
Material Total	693.52

Activity Total	4,040.32
Bill Surcharge	
Bonding 0.60%	24.24
Work Total	4,064.56
Bill Subtotal	4,064.56

For Owner/Resident Engineer's Use Only		
<input type="checkbox"/> New Bill	<input type="checkbox"/> Approved for Payment	Date of Action:
<input type="checkbox"/> Resubmittal	<input type="checkbox"/> Returned for Correction	Date Received:

Accepted:	
Customer:	Date:
Contractor:	Date: 5/8/19

Bill Total +	4,064.56
---------------------	-----------------

EXTRA WORK REPORT

CHANGE ORDER NUMBER # 2

JOB NUMBER 18049

WORK PERFORMED BY Matich Corporation

DATE PERFORMED 4-26-2019

DESCRIPTION OF WORK
saw cut, demo curb, re set curb, pour & finish ramps, 100# of sidewalk & curb feet in

DATE OF REPORT 4-26-2019

EQUIPMENT

EQP. NO.	MAKE	MODEL	HOURS	RATE	AMOUNT
7273	Pond	F550	6		
38-280	TRAILER	100,000	6		
SUBTOTAL					
MARK-UP					
TOTAL (A)					

LABOR

CRAFT	NAME			HOURS			EXTENDED TOTAL
	INT	LAST	REG	RATE	OT	RATE	
FOR	B	Koleszar	6				
LAB	A	OJEDA	6				
LAB	W	PELAYO (FWG)	6		1 1/2		
FIN	J	PEREZ	6				
FIN	E	OLIVERA	6				
FIN	M	ESCAMILLA	6				
SUBTOTAL							
LBR BURDEN							
SUBSISTENCE							
LBR MARK-UP							
TOTAL (B)							

at Club Royale town Homes added sidewalk & A curb on Linden

MATERIAL and/or WORK done by specialists or LUMP SUM or UNIT PRICE PAYMENTS:

VENDOR	INVOICE NO.	DATE	DESCRIPTION	UNITS	UNIT COST OR NET PAY	EXTENDED TOTAL
Rancho Ready Mix	588926#	4-26	Concrete 5200 2500 mix	2 cu		
SUBTOTAL						
MARK-UP						
TOTAL (A)						
TOTAL (A + B + C)						

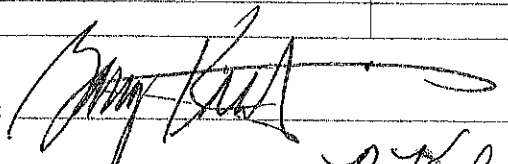
WORK AUTHORIZED BY: 
OWNER'S REPRESENTATIVE

MATCH'S REPRESENTATIVE

OFFICE USE ONLY



RANCHO READY MIX PRODUCTS, LP.

RECEIVED

MAY 06 2019

MATCH CORP.

28251 LAKE STREET • LAKE ELSINORE, CA 92530
TEL: (951) 245-2460

Page: 1

MATCH CORPORATION
P.O. BOX 10
HIGHLAND, CA 92346

Cust/Job #:
18049-MERRILL & RIVERSIDE
000089 18049-LINDEN S/O FOOTHILL
RIALTO

CUSTOMER INVOICE DATE TERMS
13068 108019 04/26/2019 10TH OF FOLLOWING MONTH

DESCRIPTION	QUANTITY UM	PRICE	AMOUNT
Ticket Number 002-129610			
520-C-2500 GREEN BOOK	04/26/2019	2.00 CY	144.00
SHORT LOAD		1.00 LD	80.00
FUEL SURCHARGE		1.00 LD	20.00
PREVAILING WAGE CHARGE		1.00 LD	220.00
ENVIRONMENTAL FEE		1.00 LD	40.00

TOTAL YARDS: 2.00 JOB TAX 39.06
 JOB TOTAL 543.06

TAXABLE AMOUNT 504.00
 EXEMPT AMOUNT 0.00
 SALES TAX 39.06
 INVOICE TOTAL 543.06

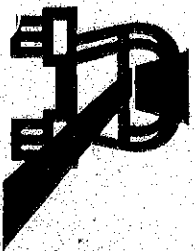

RANCHO READY MIX PRODUCTS, L.P.

Control Number: **588926**

1156 SOUTH RANCHO AVENUE COLTON, CA 92324-3341

TEL: (909) 825-3611

28251 LAKE STREET LAKE ELSINORE, CA 92530

TEL: (951) 674-0488

861 W. 4TH STREET BEAUMONT, CA 92223
TEL: (951) 845-5511

WEIGHMASTER CERTIFICATE

X MARY RICHARDSON
DEPUTY - SIGNATURE

THIS IS TO CERTIFY that the following described commodity was weighed, measured, or counted by a weighmaster, whose signature is on this certificate, who is recognized authority of accuracy, as prescribed by chapter 7 (commencing with Section 12700) of Division 5 of the California Business and Professions Code, administered by the Division of Measurement Standards of the California Department of Food and Agriculture.

CONCRETE IS A PERISHABLE COMMODITY AND BECOMES THE PROPERTY OF THE PURCHASER UPON LOADING OF THE TRUCK. Any changes or cancellation of the ordered instructions must be telephoned to the plant before loading begins. If necessary to institute legal proceedings for the collection of payment for this material, the buyer agrees to pay all court costs of such suit and such attorney fees as the court may deem just and reasonable. **NO DISCOUNTS** will be allowed and **INTEREST** will be charged on all accounts not paid by the 10TH OF THE MONTH.

CONCRETE IS A NATURAL PRODUCT therefore we cannot be responsible for variations in color or surface discoloration caused by variations in finishing techniques. We also cannot be responsible for customer supplied mix designs.

WARNING - CONCRETE in a plastic state can be **IRRITATING TO THE SKIN AND EYES.** Concrete contains Portland cement. Wear protective clothing and eyewear such as rubber boots, gloves, and safety glasses. Avoid contact with eyes and skin. **PROLONGED CONTACT MAY CAUSE BURNS.** In case of contact flush thoroughly with water. If irritation persists, get medical attention. **KEEP PLASTIC CONCRETE AWAY FROM THE CHILDREN.**

UNLOADING RELEASE

In consideration of RANCHO READY MIX PRODUCTS, L.P., hereinafter referred to as Material Dealer, delivering the purchased material to a place designated by the undersigned, the undersigned hereby releases and agrees to indemnify and hold harmless said Material Dealer, their Agents, employees and drivers from all liability or claims for damages done by it, or them, to sidewalks, driveways, roadway property and all other real and personal property adjacent thereto, as a result of the movement of said Material Dealer's vehicles or employees upon or about such property. This release is intended to, and does cover all movements of all vehicles of said Material Dealer, while being used in delivering and unloading such purchased material at the location indicated below, from the time such vehicles leave the curb line to enter upon the property described below until they return to such curb line, regardless of the number and/or dates of such deliveries or movements. Claims for storage will only be allowed at the time the material is delivered.

Plant Name: _____

SIGNATURE: _____

PORTLAND CEMENT ASSOCIATION CONTRACTOR JOINT RECOMMENDATIONS: 4" THICK FLATWORK, PEA GRAVEL MIXES 8" X 8" MIXES 10" X 10" minimum spacing (no more than 6-1 to 1.5 length to width ratio) with joint depths of 1" Isolation joints to all other structures are highly recommended. Call note information, or visit website at www.cement.org

TO JOB	ARRIVE	START	END	STAND BY	ISSUE	PLANT	TICKET #
1235	1255	100		0			
DATE	TIME	PLANT #	ORDER #	CUST #	JOB #	ZONE	PO. #
05-09-18	12:25	002	33858	13268	10049	0	
SOLD TO			TERRACE #	LICENSE	NAME	LOAD #	
RATION CORPORATION			78		RUSCO, CHRIS	1	
JOB ADDRESS	INSTRUCTIONS:						
LINDEN 5/0 FOOTBALL	MILRTO						
JOB TIME	SUMP	USAGE	WATER	WATER			
1:05	4:00	CURB & 31	505-47				
BATCH/WATER	FREE MOISTURE	MAX WATER	WATER ADDED				
			79	5			

TOTAL ORDERED	TOTAL SHIPPED	THIS TICKET	PRODUCT CODE	PRODUCT DESCRIPTION	UNITS	UNIT PRICE	EXTENSION
2.00	2.00	2.00	850055	500-C-2580 GREEN BODK	CY	.00	.00
1.00	1.00	1.00	850055	PREVAILING WAGE CHARGE	LD	.00	.00
1.00	1.00	1.00	850055	ENVIRONMENTAL FEE	LD	.00	.00
1.00	1.00	1.00	850055	FUEL SURCHARGE	LD	.00	.00
1.00	1.00	1.00	850055	SHORT LEAD	LD	.00	.00

CUSTOMER ASSUMES RESPONSIBILITIES FOR WATER ADDED BEYOND DESIGNED SLUMP.
NOTICE: Excessive water is detrimental to concrete performance.

SUBTOTAL	2.00
TAX	.00
TOTAL	2.00
PREV BAL	
SUBTOTAL	
STAND BY	
TOTAL	2.00

EX WORK
Linden

CUSTOMER COPY



August 5, 2019

CCO No. 2, ITEM
15

Willdan Engineering
13191 Crossroads Parkway North, Suite 405
Industry, CA 91746

Attn: Barry Knutson, Construction Manager

Re: 2017/18 Annual Street Overlay Project, City Project Number. 180804
Change Order Request 7.11 – Remove Existing Ramp and Replace as Directed by the City

Dear Barry:

Matich Corporation respectfully submits this correspondence as a change order request to remove and replace the existing concrete ramp at the south east corner of Larch and Merrill as directed by the City. Following completion of all other concrete improvements on Merrill Avenue, Matich was directed to return and construct the concrete ramp at the south east corner of Larch and Merrill using abnormal methods of removal and replacement not shown in the plans and specifications as the ramp was constructed over a shallow storm drain box. The work performed at this location was directed by the City after City staff had the opportunity to consider design alternatives. Please prepare a contract change order in the amount of \$8,105.72 for this work performed as directed.

Please do not hesitate to contact me with questions.

Respectfully,

Matich Corporation

A handwritten signature in black ink, appearing to read 'Jake Reade', is written over a white background.

by Jake Reade

Copy: File
Bcc:
Attachments:

DAILY EXTRA WORK REPORT

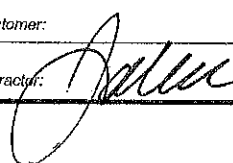
City Of Rialto Contractor Job: 18-049 - 2017/18 Annual Street Overlay Project Work Performed By: Match Corporation Description of Work: Remove Concrete & Grade ADA Ramp At S/E Corner Of Larch & Merrill		Contract: 180804	Change Order 100 Billing Number 12.0 Report Date 4/28/2019 Perform Date 4/26/2019																											
Labor Charges <table border="1" style="width: 100%; border-collapse: collapse;"> <thead> <tr> <th>Craft/Level</th> <th>Employee Name</th> <th>RT Hrs</th> <th>OT Hrs</th> <th>Subs Units</th> <th>RT Rate</th> <th>OT Rate</th> <th>Subs Rate</th> <th>Extended</th> </tr> </thead> <tbody> <tr> <td>L01 LBR LG4</td> <td>J Cinco</td> <td>8.00</td> <td></td> <td></td> <td>63.600</td> <td></td> <td></td> <td>508.80</td> </tr> <tr> <td>L02 LBR LG1</td> <td>J Bautista</td> <td>8.00</td> <td></td> <td></td> <td>60.640</td> <td></td> <td></td> <td>485.12</td> </tr> </tbody> </table>			Craft/Level	Employee Name	RT Hrs	OT Hrs	Subs Units	RT Rate	OT Rate	Subs Rate	Extended	L01 LBR LG4	J Cinco	8.00			63.600			508.80	L02 LBR LG1	J Bautista	8.00			60.640			485.12	Labor Charges RT Labor 993.92 OT Labor 0.00 Subtotal Labor 993.92 Subsistence 0.00 Other Expenses 0.00 MU 20.00% <u>198.78</u> Labor Total 1,192.70
Craft/Level	Employee Name	RT Hrs	OT Hrs	Subs Units	RT Rate	OT Rate	Subs Rate	Extended																						
L01 LBR LG4	J Cinco	8.00			63.600			508.80																						
L02 LBR LG1	J Bautista	8.00			60.640			485.12																						
Equipment Charges <table border="1" style="width: 100%; border-collapse: collapse;"> <thead> <tr> <th>Equipment ID</th> <th>Class</th> <th>Make</th> <th>Model</th> <th>A1</th> <th>A2</th> <th>RT Hrs</th> <th>OT Hrs</th> <th>RT Rate</th> <th>OT Rate</th> <th>Delay Factor</th> <th>Extended</th> </tr> </thead> <tbody> <tr> <td>E01 7271</td> <td>TRUCK</td> <td>T&TT</td> <td>12-20</td> <td></td> <td></td> <td>8.00</td> <td></td> <td>38.380</td> <td></td> <td></td> <td>307.04</td> </tr> </tbody> </table>			Equipment ID	Class	Make	Model	A1	A2	RT Hrs	OT Hrs	RT Rate	OT Rate	Delay Factor	Extended	E01 7271	TRUCK	T&TT	12-20			8.00		38.380			307.04	Equipment Charges Subtotal 307.04 MU 15.00% <u>46.06</u> Equipment Total 353.10			
Equipment ID	Class	Make	Model	A1	A2	RT Hrs	OT Hrs	RT Rate	OT Rate	Delay Factor	Extended																			
E01 7271	TRUCK	T&TT	12-20			8.00		38.380			307.04																			
Material/Specialist Work/Lump Sum or Unit Price Payment <table border="1" style="width: 100%; border-collapse: collapse;"> <thead> <tr> <th>Number</th> <th>Date</th> <th>Vendor Name and Description</th> <th>Units</th> <th>Unit Price</th> <th>Extended</th> </tr> </thead> <tbody> <tr> <td>M01 -</td> <td>4/26/2019</td> <td>Hixson Backhoe Service Inc / 580 Case Backhoe</td> <td>8.000 HR</td> <td>155.00000</td> <td>1,240.00</td> </tr> <tr> <td>M02 -</td> <td>4/26/2019</td> <td>A.C. Byers Trucking Inc. / Super 10 Wheeler</td> <td>3.000 HR</td> <td>90.00000</td> <td>270.00</td> </tr> <tr> <td>M03 -</td> <td>4/26/2019</td> <td>North American Recycling & Crushing, LLC / Dump Fees</td> <td>2.000 EA</td> <td>110.00000</td> <td>220.00</td> </tr> </tbody> </table>			Number	Date	Vendor Name and Description	Units	Unit Price	Extended	M01 -	4/26/2019	Hixson Backhoe Service Inc / 580 Case Backhoe	8.000 HR	155.00000	1,240.00	M02 -	4/26/2019	A.C. Byers Trucking Inc. / Super 10 Wheeler	3.000 HR	90.00000	270.00	M03 -	4/26/2019	North American Recycling & Crushing, LLC / Dump Fees	2.000 EA	110.00000	220.00	Material Charges Subtotal 1,730.00 MU 15.00% <u>259.50</u> Material Total 1,989.50			
Number	Date	Vendor Name and Description	Units	Unit Price	Extended																									
M01 -	4/26/2019	Hixson Backhoe Service Inc / 580 Case Backhoe	8.000 HR	155.00000	1,240.00																									
M02 -	4/26/2019	A.C. Byers Trucking Inc. / Super 10 Wheeler	3.000 HR	90.00000	270.00																									
M03 -	4/26/2019	North American Recycling & Crushing, LLC / Dump Fees	2.000 EA	110.00000	220.00																									
			Activity Total 3,535.30																											
			Bill Surcharge Bonding 0.60% 21.21																											
			Work Total 3,556.51																											
			Bill Subtotal 3,556.51																											
For Owner/Resident Engineer's Use Only <input type="checkbox"/> New Bill <input type="checkbox"/> Approved for Payment Date of Action: <input type="checkbox"/> Resubmittal <input type="checkbox"/> Returned for Correction Date Received:			Accepted: Customer: _____ Date: _____ Contractor:  Date: 5/8/19																											
			Bill Total + 3,556.51																											

HIYXSON BACKHOE SERVICE INC



INVOICE

PO BOX 715
 MURRIETA, CA 92564-0715
 (951) 677-6212 * FAX (951) 677-3894
 CSLB #956710 * SE(Micro)

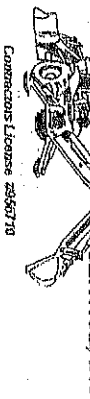

DATE	INVOICE NO.
4/27/2019	29306

BILL TO
 Match Corporation
 P.O. Box 10
 Highland, CA 92346

JOB LOCATION
 Yucca Ave & Merrill Ave
 Rialto, CA
 Dir #267433
RECEIVED
 MAY 06 2019
 MATCH CORP.

P.O. NO.	TERMS	JOB #
	30 days	18-049

DATE	DESCRIPTION	TICKET #	HOURS	RATE	AMOUNT
4/22/2019	580 Backhoe W/Operator	36706	8	155.00	1,240.00
4/23/2019	580 Backhoe W/Operator	36707	8	155.00	1,240.00
4/24/2019	580 Backhoe W/Operator	36708	8	155.00	1,240.00
4/25/2019	580 Backhoe W/Operator	36709	8	155.00	1,240.00
4/26/2019	580 Backhoe W/Operator	36710	8	155.00	1,240.00
4/22/2019	580 Backhoe W/Operator	37414	6	155.00	930.00
4/23/2019	580 Backhoe W/Operator	37405	7	155.00	1,085.00
4/23/2019	580 Backhoe W/Atlas Breaker	37405	1	207.00	207.00
4/24/2019	580 Backhoe W/Operator	37406	8	155.00	1,240.00
4/25/2019	580 Backhoe W/Operator	37407	7	155.00	1,085.00
4/26/2019	580 Backhoe W/Operator	37408	8	155.00	1,240.00
	<u>18049</u>				
	40W-3: \$1,550 -				
	505-3: \$1,240 -				
	506-1: \$2,007 -				
	506-3: \$1,860 -				
	W01-4: \$405 -				
	W02-2: \$2,325 -				
	W02-3: \$930 -				
	700-4: \$1,240 -				
	700-5: \$310 -				

Certified Payroll - Submitted on LCP TRACKER & CA DIR eCPR -
 Thank You **Total \$11,987.00**

HIXSON BACKHOE SERVICE, INC.
P.O. Box 0715, Murietta, CA 92564-0715 • (951) 677-6212 • FAX (951) 677-3894

№ 36710

WORK FOR WATTICK PO# 18-099
JOB LOCATION ROACTO JOB #

DATE	HOURS	EQUIPMENT	WORK DONE AS DIRECTED
4-26-14	8	580 #1	18-099 700-4 extra work 8 hrs Larch/Mentill

NOTICE: OUR OPERATORS WILL MAKE EVERY EFFORT TO PROTECT AND AVOID DAMAGE TO UNDERGROUND STRUCTURES. WE WILL ASSUME NO RESPONSIBILITY FOR DAMAGES UNLESS HAZARDS EXPOSED AND DAMAGES NOTED ON THIS INVOICE. IT IS HEREBY AGREED THAT COSTS ARISING FOR COLLECTION OF AMOUNT DUE SUCH AS ATTORNEY FEES, EXPENSES AND COURT COSTS WILL BE PAID BY CONTRACTOR. NO CLAIMS ALLOWED AFTER 10 DAYS FROM DATE OF INVOICE.

OPERATOR [Signature] BY [Signature]

A. C. BYERS TRUCKING INC.

210 S. "G" STREET

SAN BERNARDINO CA 92410-3309

Office: 909-884-6064 Fax: 909-884-5024

CA #017617

Date: 05/06/19

Invoice: 201905-78

Job: 04/01/19-75

Cust. # MATICHC

Customer Job: 19-005

MATCH CORPORATION
P.O. BOX 10
HIGHLAND CA 92346

Origin:

Destination:

Date	Truck	Fl Bill	Description	Qty	Rate	Amount
04/24	461A	2709409		6.00	90.00	540.00
04/24	461A	3060261		6.00	90.00	540.00
04/24	461A	3206360		5.50	90.00	495.00
04/24	461A	4202318		8.00	90.00	720.00
04/26	1584	4016753		6.00	90.00	540.00
04/26	461A	4202319		4.00	90.00	360.00

TOTAL: 3,195.00

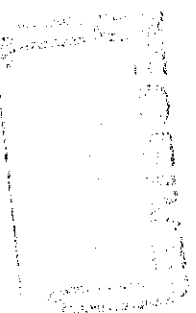

NON-NEGOTIABLE BILL-OF-LADING AND TRANSPORTATION AGREEMENT

BILL NO.

DATE 4-26-19 JOB # A-4016753

PRINCIPAL CARRIER Oyers Trucking

ADDRESS _____ PH. _____

CITY/STATE/ZIP _____ PH. _____

UNDERLYING CARRIER (IF ANY) GOVDIRT TRANSPORT TRUCK # 699

ADDRESS _____ PH. _____

SHIPPER MATCH CORP. RECEIVER _____ TRAILER # _____

ADDRESS _____ PH. _____

CITY/STATE/ZIP _____ ADDRESS _____

POINT OF ORIGIN MERRILL - LOAD, RIATRO POINT OF DESTINATION MERRIMACK LADGELL

EQUIPMENT TYPE SUPER TAG END DUMP FLAT BED PER LOAD

10 WHEELER TRANSFER SIDE DUMP MIXER

SUPER-10 DBL BOTTOMS TRUCK & PUP SWEEPER

STRONG ARM SEMI-BOTTOM WALKER TRUCK OTHER 37818 RATE @ \$ _____

TAG NO	WEIGHT	COMMODITY	LOADING		UNLOADING		STANDBY TIME	BREAKDOWN/REASON FOR DELAY						
			ARRIVE	DEPART	ARRIVE	DEPART								
1	1111	DIRT												
2														
3														
4														
5														
6														
7														
8														
9														
10														
11														
12														
13														
14														
15														
REPORTING TIME			ENDING TIME		TOTAL TIME		DEDUCTIBLE TIME		NET TIME		TOTAL TONS		ACCESSORIAL OTHER	
9:00			3:00		6		6		6					
START DRIVING TIME LAST TRIP			ARRIVAL TIME AT DUMP LAST TRIP		END LOADING LAST TRIP		RUNNING TIME LAST TRIP		SUBJECT TO TERMS AND CONDITIONS ON REVERSE SIDE		TOTAL CHARGES			

18-049 19.8 hrs total
601-5 = 16.8 hrs
12 loads
extra work = 3 hrs
Load / Merrill

Got DIRT DRIVER SIGNATURE _____ SHIPPER/RECEIVER (AGENT OR DEBITOR) SIGNATURE _____ JOB _____



**NORTH AMERICAN
RECYCLING AND CRUSHING, LLC**

SHIP TO: STREET IMPROVEMENTS QUOTE 91346A / RIALTO
S LINDEN AVE & W MERRILL AVE / RIALTO
STREET IMPROVEMENTS QUOTE 91346A / RIALTO
S LINDEN AVE & W MERRILL AVE / RIALTO
BLOOMINGTON, CA

CUSTOMER NO: 1928986-3750892
INVOICE NO: 72181055
INVOICE DATE: 4/29/2019
INVOICE AMT: 220.00
ORDER: 631244
DUE DATE: 5/15/2019

MATCH CORPORATION
1596 HARRY SHEPPARD BLVD
SAN BERNARDINO, CA 92408

To ensure proper credit, please include remittance or list invoice numbers on your check remittance and send to:
North American Crushing and Recycling
P.O. Box 743662
Los Angeles, CA 90074-3662
714-777-6400 or help@NARecycle.com

INVOICE

PLEASE DETACH AND RETURN WITH REMITTANCE TAX-EXEMPT I.D.:

SALES REP	LOCATION	PO NUMBER	REF	CONTRACT NO.				
15001 Aaron Waddell	COLTON RECYCLE	JOSE						
INVOICE #	INVOICE DATE	CUSTOMER NUMBER	LOCATION	ORDER	BILL OF LADING	FOR		
72181055	4/29/2019	1928986-3750892	4936-171	631244		PICKUP		
SHIP DATE	TICKET	VEHICLE	PROD. CODE	DESCRIPTION	UOM	QUANTITY	PRICE	AMOUNT
4/26/2019	34404474	2977	SLZT1	S10 DUMP FEES - MIXED	Load	1.00	110.00	110.00
4/26/2019	34404478	2977	SLZT1	S10 DUMP FEES - MIXED	Load	1.00	110.00	110.00
						2.00*		220.00*
Total Quantity	2.00	Taxes	<div style="border: 1px solid black; border-radius: 50%; padding: 10px; width: fit-content; margin: 0 auto;"> <p>18049 700-4 \$ 220- M.A. 5/17</p> </div>		Percent	Amt	Sales Tax	
Total Freight								
TERMS: NET 15th PROX - Payable in full by the 15th of each month following month of shipment.								
Invoice not valid according to our credit terms will be assessed a Finance Charge. Customer shall pay all cost of collection including but not limited to a reasonable attorney's fee for services rendered by suit or otherwise in collecting past due invoices.								
Total Invoice							\$ 220.00	



Shipping Location:

COLTON RECYCLE
1120 SOUTH LA CADENA DRIVE

North American Recycling and Crushing, LLC

COLTON, CA 92324

Danger
Read important health information on reverse.
Peligro
Léase la información importante para la salud en el reverso.

RECEIVED BY: **X** CUSTOMER/CONSIGNEE:

DATE: 4/26/2019 TIME: DRIVER 8:24AM PLANT: 4936-171 COLTON RECYCLE TICKET NO: 34404474

WEIGHMASTER CERTIFICATE: THIS IS TO CERTIFY that the following described commodity was weighed, measured or counted by a weighmaster, whose signature is on the certificate, who is a recognized authority of accuracy, as prescribed by Chapter 7 (commencing with Section 12700) of Division 5 of the California Business and Professions Code, administered by the Division of Measurement Standards of the California Department of Food and Agriculture

WEIGHMASTER DEPUTY: JANE WEINMANN

LIMITED WARRANTY AND WARRANTY DISCLAIMER: Seller warrants for a period of one (1) year from date of delivery only that the material sold hereunder substantially complies with Seller's specification for said material or the specifications set forth in Seller's quotation. SELLER HEREBY EXCLUDES ALL WARRANTIES OF MERCHANTABILITY AND FITNESS FOR ANY PURPOSE, AND ALL OTHER WARRANTIES, EXPRESS OR IMPLIED, OF THE MATERIAL SOLD HEREUNDER, OTHER THAN THE EXPRESS WARRANTY STATED ABOVE. In addition, except to the extent otherwise set forth in the specification described above, Seller makes no warranty whatsoever with respect to specific gravity, absorption, whether the material is innocuous, non-deleterious, or non-reactive, or whether the material is in conformance with any plans, other specifications, regulations, ordinances, statutes, or other standards applicable to customer's job or to said material as used by customer, SELLER SHALL IN NO EVENT BE RESPONSIBLE FOR ANY INCIDENTAL OR CONSEQUENTIAL DAMAGE CAUSED BY NON-COMPLIANCE OF THE MATERIAL WITH SPECIFICATION, OR FOR ANY DEFECTS IN THE MATERIALS SOLD HEREUNDER.

ALL SALES AND DELIVERS MADE SUBJECT TO SELLER'S GENERAL TERMS AND CONDITIONS.

AS EVIDENCED BY SIGNATURE, OR DEPARTURE FROM SELLER'S FACILITY, CARRIER ACKNOWLEDGES THAT CARRIER IS SOLELY RESPONSIBLE FOR THE ACCURACY OF THIS VEHICLE'S TARE WEIGHT, AXLE WEIGHTS AND GROSS WEIGHT. CARRIER SHALL BE RESPONSIBLE FOR NOTIFYING SELLER WHEN ANY TRUCK OR TRAILER HAS BEEN OVERLOADED SO AS TO RENDER IT OUT OF COMPLIANCE WITH ANY APPLICABLE WEIGHT LIMITS. TO THE MAXIMUM EXTENT ALLOWED BY LAW, CARRIER SHALL INDEMNIFY SELLER FOR ANY LOSS CAUSED BY OVERLOADING.

TRUCK TARE AND GROSS WEIGHTS ARE DETERMINED WITH THE DRIVER IN THE VEHICLE.

CUSTOMER: 3750892 CK#		CUSTOMER PURCHASE ORDER: JOSE		GOVT CONTRACT:	
ORDER: 631244	STREET IMPROVEMENTS QUOTE 91346A / RIALTO S LINDEN AVE & W MERRILL AVE / RIALTO			PICKED UP	
DESTINATION: RIALTO	STREET IMPROVEMENTS QUOTE 91346A / RIALTO S LINDEN AVE & W MERRILL AVE / RIALTO VALLEY			ZONE/MILES 7 MILES	
PRODUCT: 8LZT1	S10 DUMP FEES - MIXED				
COMMENTS: 18-049 extra work load and Merrill ramp S/E corner					
TRUCK 2977	S-10	CARRIER W089	CUSTOMER PICKED UP		
LICENSE 7N42977	SIMPLE16-20	TRAILER ID NO	TRAILER ID NO		
FREIGHT TYPE L	AXLES 0	TARE DATE 12/30/1899	TARE EXPIRE 01/07/1900		
GROSS LBS (Scale 0)	TARE LBS (Scale 0)	NET LBS	LOADS TODAY	LOADS TODAY	LOADS TODAY
0	0	0	1.00	1.00	1
GROSS KG	TARE KG	NET KG	IN PLANT	OUT OF PLANT	
0	0	0	12:00 am	8:24AM	
CASH SALE PER TON	MATERIAL	HAUL	TAX	OTHER CHARGES	TOTAL
TOTAL	MATERIAL	HAUL	TAX	OTHER CHARGES	TOTAL
FREIGHT TIME	ARRIVE JOB	START UNLOAD	FINISH UNLOAD	JOB TIME	DELAY TIME

CA REG906-2 Rev. 09/16 We make deliveries inside the curb line at the customer's risk only and accept no responsibility whatsoever for damage resulting from such deliveries.



Shipping Location:

COLTON RECYCLE
1120 SOUTH LA CADENA DRIVE

North American Recycling and Crushing, LLC

COLTON, CA 92324

Danger
Read important health information on reverse.
Peligro
Léase la información importante para la salud en el reverso.

RECEIVED BY: **X** CUSTOMER/CONSIGNEE:

DATE: 4/26/2019 TIME: DRIVER 8:24AM PLANT: 4936-171 COLTON RECYCLE TICKET NO: 34404474

WEIGHMASTER CERTIFICATE: THIS IS TO CERTIFY that the following described commodity was weighed, measured or counted by a weighmaster, whose signature is on the certificate, who is a recognized authority of accuracy, as prescribed by Chapter 7 (commencing with Section 12700) of Division 5 of the California Business and Professions Code, administered by the Division of Measurement Standards of the California Department of Food and Agriculture

WEIGHMASTER DEPUTY: JANE WEINMANN

LIMITED WARRANTY AND WARRANTY DISCLAIMER: Seller warrants for a period of one (1) year from date of delivery only that the material sold hereunder substantially complies with Seller's specification for said material or the specifications set forth in Seller's quotation. SELLER HEREBY EXCLUDES ALL WARRANTIES OF MERCHANTABILITY AND FITNESS FOR ANY PURPOSE, AND ALL OTHER WARRANTIES, EXPRESS OR IMPLIED, OF THE MATERIAL SOLD HEREUNDER, OTHER THAN THE EXPRESS WARRANTY STATED ABOVE. In addition, except to the extent otherwise set forth in the specification described above, Seller makes no warranty whatsoever with respect to specific gravity, absorption, whether the material is innocuous, non-deleterious, or non-reactive, or whether the material is in conformance with any plans, other specifications, regulations, ordinances, statutes, or other standards applicable to customer's job or to said material as used by customer, SELLER SHALL IN NO EVENT BE RESPONSIBLE FOR ANY INCIDENTAL OR CONSEQUENTIAL DAMAGE CAUSED BY NON-COMPLIANCE OF THE MATERIAL WITH SPECIFICATION, OR FOR ANY DEFECTS IN THE MATERIALS SOLD HEREUNDER.

ALL SALES AND DELIVERS MADE SUBJECT TO SELLER'S GENERAL TERMS AND CONDITIONS.

AS EVIDENCED BY SIGNATURE, OR DEPARTURE FROM SELLER'S FACILITY, CARRIER ACKNOWLEDGES THAT CARRIER IS SOLELY RESPONSIBLE FOR THE ACCURACY OF THIS VEHICLE'S TARE WEIGHT, AXLE WEIGHTS AND GROSS WEIGHT. CARRIER SHALL BE RESPONSIBLE FOR NOTIFYING SELLER WHEN ANY TRUCK OR TRAILER HAS BEEN OVERLOADED SO AS TO RENDER IT OUT OF COMPLIANCE WITH ANY APPLICABLE WEIGHT LIMITS. TO THE MAXIMUM EXTENT ALLOWED BY LAW, CARRIER SHALL INDEMNIFY SELLER FOR ANY LOSS CAUSED BY OVERLOADING.

TRUCK TARE AND GROSS WEIGHTS ARE DETERMINED WITH THE DRIVER IN THE VEHICLE.

CUSTOMER: 3750892 CK#		CUSTOMER PURCHASE ORDER: JOSE		GOVT CONTRACT:	
ORDER: 631244	STREET IMPROVEMENTS QUOTE 91346A / RIALTO S LINDEN AVE & W MERRILL AVE / RIALTO			PICKED UP	
DESTINATION: RIALTO	STREET IMPROVEMENTS QUOTE 91346A / RIALTO S LINDEN AVE & W MERRILL AVE / RIALTO VALLEY			ZONE/MILES 7 MILES	
PRODUCT: 8LZT1	S10 DUMP FEES - MIXED				
COMMENTS:					
TRUCK 2977	S-10	CARRIER W089	CUSTOMER PICKED UP		
LICENSE 7N42977	SIMPLE16-20	TRAILER ID NO	TRAILER ID NO		
FREIGHT TYPE L	AXLES 0	TARE DATE 12/30/1899	TARE EXPIRE 01/07/1900		
GROSS LBS (Scale 0)	TARE LBS (Scale 0)	NET LBS	LOADS TODAY	LOADS TODAY	LOADS TODAY
0	0	0	1.00	1.00	1
GROSS KG	TARE KG	NET KG	IN PLANT	OUT OF PLANT	
0	0	0	12:00 am	8:24AM	
CASH SALE PER TON	MATERIAL	HAUL	TAX	OTHER CHARGES	TOTAL
TOTAL	MATERIAL	HAUL	TAX	OTHER CHARGES	TOTAL
FREIGHT TIME	ARRIVE JOB	START UNLOAD	FINISH UNLOAD	JOB TIME	DELAY TIME

CA REG906-2 Rev. 09/16 We make deliveries inside the curb line at the customer's risk only and accept no responsibility whatsoever for damage resulting from such deliveries.

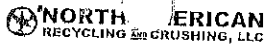

Shipping Location:

COLTON RECYCLE
1120 SOUTH LA CADENA DRIVE

North American Recycling and Crushing, LLC

COLTON, CA 92324

Danger			
Read important health information on reverse.			
Peligro			
Léase la información importante para la salud en el reverso.			
RECEIVED BY: X		CUSTOMER/CONSIGNEE:	
DATE: 4/26/2019	TIME: DRIVER 9:37AM	PLANT: 4936-171 COLTON RECYCLE	TICKET NO: 34404478

WEIGHMASTER CERTIFICATE: THIS IS TO CERTIFY that the following described commodity was weighed, measured, or counted by a weighmaster, whose signature is on the certificate, who is a recognized authority of accuracy, as prescribed by Chapter 7 (commencing with Section 12700) of Division 5 of the California Business and Professions Code, administered by the Division of Measurement Standards of the California Department of Food and Agriculture

WEIGHMASTER DEPUTY: JANE WEINMANN

LIMITED WARRANTY AND WARRANTY DISCLAIMER: Seller warrants for a period of one (1) year from date of delivery only that the material sold hereunder substantially complies with Seller's specification for said material or the specifications set forth in Seller's quotation. SELLER HEREBY EXCLUDES ALL WARRANTIES OF MERCHANTABILITY AND FITNESS FOR ANY PURPOSE, AND ALL OTHER WARRANTIES, EXPRESS OR IMPLIED, OF THE MATERIAL SOLD HEREUNDER, OTHER THAN THE EXPRESS WARRANTY STATED ABOVE. In addition, except to the extent otherwise set forth in the specification described above, Seller makes no warranty whatsoever with respect to specific gravity, absorption, whether the material is innocuous, non-deleterious, or non-reactive, or whether the material is in conformance with any plans, other specifications, regulations, ordinances, statutes, or other standards applicable to customer's job or to said material as used by customer. SELLER SHALL IN NO EVENT BE RESPONSIBLE FOR ANY INCIDENTAL OR CONSEQUENTIAL DAMAGE CAUSED BY NON-COMPLIANCE OF THE MATERIAL WITH SPECIFICATION, OR FOR ANY DEFECTS IN THE MATERIALS SOLD HEREUNDER.

ALL SALES AND DELIVERS MADE SUBJECT TO SELLER'S GENERAL TERMS AND CONDITIONS.

AS EVIDENCED BY SIGNATURE, OR DEPARTURE FROM SELLER'S FACILITY, CARRIER ACKNOWLEDGES THAT CARRIER IS SOLELY RESPONSIBLE FOR THE ACCURACY OF THIS VEHICLE'S TARE WEIGHT, AXLE WEIGHTS AND GROSS WEIGHT. CARRIER SHALL BE RESPONSIBLE FOR NOTIFYING SELLER WHEN ANY TRUCK OR TRAILER HAS BEEN OVERLOADED SO AS TO RENDER IT OUT OF COMPLIANCE WITH ANY APPLICABLE WEIGHT LIMITS. TO THE MAXIMUM EXTENT ALLOWED BY LAW, CARRIER SHALL INDEMNIFY SELLER FOR ANY LOSS CAUSED BY OVERLOADING.

TRUCK TARE AND GROSS WEIGHTS ARE DETERMINED WITH THE DRIVER IN THE VEHICLE.

CUSTOMER: 3750892 CK#		CUSTOMER PURCHASE ORDER:		GOVT CONTRACT:	
MATCH CORPORATION		JOSE			
ORDER:	STREET IMPROVEMENTS QUOTE 91346A / RIALTO			PICKED UP	
631244	S LINDEN AVE & W MERRILL AVE / RIALTO				
DESTINATION:	STREET IMPROVEMENTS QUOTE 91346A / RIALTO			ZONE/MILES	
RIALTO	S LINDEN AVE & W MERRILL AVE / RIALTO VALLEY			7 MILES	
PRODUCT:	8LZT1 S10 DUMP FEES - MIXED				
COMMENTS:					
TRUCK 2977	S-10	CARRIER W089		CUSTOMER PICKED UP	
LICENSE 7N42977	SIMPLE16-20	TRAILER ID NO		TRAILER ID NO	
FREIGHT TYPE L	AXLES 0	TARE DATE 12/30/1899		TARE EXPIRE 01/07/1900	
GROSS LBS (Scale 0)	TARE LBS (Scale 0)	NET LBS	LOADS	LOADS TODAY	LOADS TODAY
0	0	0	1.00	2.00	2
GROSS KG	TARE KG	NET KG	IN PLANT		OUT OF PLANT
0	0	0	12:00 am		9:37AM
CASH SALE PER TON	MATERIAL	HAUL			
TOTAL	MATERIAL	HAUL	TAX	OTHER CHARGES	GOD TOTAL
FREIGHT TIME REPORT	ARRIVE JOB	START UNLOAD	FINISH UNLOAD	JOB TIME	DELAY TIME

We make deliveries inside the curb line at the customer's risk only and accept no responsibility whatsoever for damage resulting from such deliveries.



Shipping Location:

COLTON RECYCLE
1120 SOUTH LA CADENA DRIVE

North American Recycling and Crushing, LLC

COLTON, CA 92324

Danger			
Read important health information on reverse.			
Peligro			
Léase la información importante para la salud en el reverso.			
RECEIVED BY: X		CUSTOMER/CONSIGNEE:	
DATE: 4/26/2019	TIME: DRIVER 9:37AM	PLANT: 4936-171 COLTON RECYCLE	TICKET NO: 34404478

WEIGHMASTER CERTIFICATE: THIS IS TO CERTIFY that the following described commodity was weighed, measured, or counted by a weighmaster, whose signature is on the certificate, who is a recognized authority of accuracy, as prescribed by Chapter 7 (commencing with Section 12700) of Division 5 of the California Business and Professions Code, administered by the Division of Measurement Standards of the California Department of Food and Agriculture

WEIGHMASTER DEPUTY: JANE WEINMANN

LIMITED WARRANTY AND WARRANTY DISCLAIMER: Seller warrants for a period of one (1) year from date of delivery only that the material sold hereunder substantially complies with Seller's specification for said material or the specifications set forth in Seller's quotation. SELLER HEREBY EXCLUDES ALL WARRANTIES OF MERCHANTABILITY AND FITNESS FOR ANY PURPOSE, AND ALL OTHER WARRANTIES, EXPRESS OR IMPLIED, OF THE MATERIAL SOLD HEREUNDER, OTHER THAN THE EXPRESS WARRANTY STATED ABOVE. In addition, except to the extent otherwise set forth in the specification described above, Seller makes no warranty whatsoever with respect to specific gravity, absorption, whether the material is innocuous, non-deleterious, or non-reactive, or whether the material is in conformance with any plans, other specifications, regulations, ordinances, statutes, or other standards applicable to customer's job or to said material as used by customer. SELLER SHALL IN NO EVENT BE RESPONSIBLE FOR ANY INCIDENTAL OR CONSEQUENTIAL DAMAGE CAUSED BY NON-COMPLIANCE OF THE MATERIAL WITH SPECIFICATION, OR FOR ANY DEFECTS IN THE MATERIALS SOLD HEREUNDER.

ALL SALES AND DELIVERS MADE SUBJECT TO SELLER'S GENERAL TERMS AND CONDITIONS.

AS EVIDENCED BY SIGNATURE, OR DEPARTURE FROM SELLER'S FACILITY, CARRIER ACKNOWLEDGES THAT CARRIER IS SOLELY RESPONSIBLE FOR THE ACCURACY OF THIS VEHICLE'S TARE WEIGHT, AXLE WEIGHTS AND GROSS WEIGHT. CARRIER SHALL BE RESPONSIBLE FOR NOTIFYING SELLER WHEN ANY TRUCK OR TRAILER HAS BEEN OVERLOADED SO AS TO RENDER IT OUT OF COMPLIANCE WITH ANY APPLICABLE WEIGHT LIMITS. TO THE MAXIMUM EXTENT ALLOWED BY LAW, CARRIER SHALL INDEMNIFY SELLER FOR ANY LOSS CAUSED BY OVERLOADING.

TRUCK TARE AND GROSS WEIGHTS ARE DETERMINED WITH THE DRIVER IN THE VEHICLE.

CUSTOMER: 3750892 CK#		CUSTOMER PURCHASE ORDER:		GOVT CONTRACT:	
MATCH CORPORATION		JOSE			
ORDER:	STREET IMPROVEMENTS QUOTE 91346A / RIALTO			PICKED UP	
631244	S LINDEN AVE & W MERRILL AVE / RIALTO				
DESTINATION:	STREET IMPROVEMENTS QUOTE 91346A / RIALTO			ZONE/MILES	
RIALTO	S LINDEN AVE & W MERRILL AVE / RIALTO VALLEY			7 MILES	
PRODUCT:	8LZT1 S10 DUMP FEES - MIXED				
COMMENTS:					
TRUCK 2977	S-10	CARRIER W089		CUSTOMER PICKED UP	
LICENSE 7N42977	SIMPLE16-20	TRAILER ID NO		TRAILER ID NO	
FREIGHT TYPE L	AXLES 0	TARE DATE 12/30/1899		TARE EXPIRE 01/07/1900	
GROSS LBS (Scale 0)	TARE LBS (Scale 0)	NET LBS	LOADS	LOADS TODAY	LOADS TODAY
0	0	0	1.00	2.00	2
GROSS KG	TARE KG	NET KG	IN PLANT		OUT OF PLANT
0	0	0	12:00 am		9:37AM
CASH SALE PER TON	MATERIAL	HAUL			
TOTAL	MATERIAL	HAUL	TAX	OTHER CHARGES	GOD TOTAL
FREIGHT TIME REPORT	ARRIVE JOB	START UNLOAD	FINISH UNLOAD	JOB TIME	DELAY TIME

We make deliveries inside the curb line at the customer's risk only and accept no responsibility whatsoever for damage resulting from such deliveries.

DAILY EXTRA WORK REPORT

City Of Rialto	Contract: 180804	Change Order 100
Contractor Job: 18-049 - 2017/18 Annual Street Overlay Project		Billing Number 13.0
Work Performed By: Matich Corporation		Report Date 5/08/2019
Description of Work: Pour Single Ramp At S/E Corner Of Larch & Merrill		Perform Date 4/29/2019

Labor Charges								
Craft/Level	Employee Name	RT Hrs	OT Hrs	Subs Units	RT Rate	OT Rate	Subs Rate	Extended
L01 OE OF8	B Koleszar	5.00	0.50		83.340	110.110		471.76
L02 OE OF8	B Koleszar		0.50			137.130		68.57
L03 LBR LG4	A Ojeda	5.00	0.50		63.600	103.070		369.54
L04 LBR LG3	W Pelayo	5.00	0.50		61.870	99.670		359.19
L05 CMTMS LG5	J Perez	5.00	0.50		66.360	104.600		384.10
L06 CMTMS LG5	M Escamilla	5.00	0.50		66.360	104.600		384.10
L07 CMTMS LG5	E Olvera	5.00	0.50		66.360	104.600		384.10

Labor Charges	
RT Labor	2,039.45
OT Labor	381.91
Subtotal Labor	2,421.36
Subsistence	0.00
Other Expenses	0.00
MU 20.00%	484.27
Labor Total	2,905.63

Equipment Charges											
Equipment ID	Class	Make	Model	A1	A2	RT Hrs	OT Hrs	RT Rate	OT Rate	Delay Factor	Extended
E01 7273	TRUCK T&TT		12-20			5.00		38.380			191.90

Equipment Charges	
Subtotal	191.90
MU 15.00%	28.79
Equipment Total	220.69

Material/Specialist Work/Lump Sum or Unit Price Payment						
Number	Date	Vendor Name and Description	Units	Unit Price	Extended	
M01 38283	4/29/2019	Matich Corporation / Big Tex Utility Trailer	5.000 HR	10.00000	50.00	
M02 108061	4/29/2019	Rancho Ready Mix Products, L.P. / 660-CW-4000	1.000 LS	1,163.70000	1,163.70	

Material Charges	
Subtotal	1,213.70
MU 15.00%	182.06
Material Total	1,395.76

Activity Total **4,522.08**

Bill Surcharge		
Bonding	0.60%	27.13

Work Total **4,549.21**

Bill Subtotal **4,549.21**

For Owner/Resident Engineer's Use Only			
<input type="checkbox"/> New Bill	<input type="checkbox"/> Approved for Payment	Date of Action:	
<input type="checkbox"/> Resubmittal	<input type="checkbox"/> Returned for Correction	Date Received:	

Accepted:	
Customer:	Date: _____
Contractor:	Date: 5/9/19

Bill Total + **4,549.21**

EXTRA WORK REPORT

CHANGE ORDER NUMBER _____

JOB NUMBER 18-049

WORK PERFORMED BY MATICH Corp

DATE PERFORMED 4-29-19

DESCRIPTION OF WORK Poured 1 single Ramp SE LARCH

DATE OF REPORT 5-8-19

EQUIPMENT

EQP. NO.	MAKE	MODEL	HOURS	RATE	AMOUNT
7273	Ford	F550	5		
88283	B.G. Tex	Trail	5		
				SUBTOTAL	
				MARK-UP	
				TOTAL (A)	

LABOR

CRAFT	INT	NAME LAST	REG	RATE	HOURS		DT RATE	EXTENDED TOTAL
					OT			
OFB	B	Koleszar	5			5	1.5	
L4	A	osepa	5				1.5	
L3	W	Perino	5				1.5	
cm	J	Perez	5				1.5	
cm	m	Escamilla	5				1.5	
cm	E	OLVERA	5				1.5	
							SUBTOTAL	
							LBR BURDEN	
							SUBSISTENCE	
							LBR MARK-UP	
							TOTAL (B)	

MATERIAL and/or WORK done by specialists or LUMP SUM or UNIT PRICE PAYMENTS:

VENDOR	INVOICE NO.	DATE	DESCRIPTION	UNITS	UNIT COST OR NET PAY	EXTENDED TOTAL
Rancho Ready Mix		4-29-19	4000 PST	10 yds		
					SUBTOTAL	
					MARK-UP	
					TOTAL (A)	

WORK AUTHORIZED BY:

[Signature]
OWNER'S REPRESENTATIVE

OFFICE USE ONLY

[Signature]
MATICH'S REPRESENTATIVE

TOTAL (A + B + C)

KNOW WORK WAS DONE

1 ORIGINAL - JOB FILE

2ND COPY - CUSTOMER

3RD COPY - BILLING

4TH COPY - REMAIN IN BOOK

FORM 1207



RANCHO READY MIX PRODUCTS, L.P.

RECEIVED

MAY 06 2019

28251 LAKE STREET • LAKE ELSINORE, CA 92530
TEL: (951) 245-2460

MATICH CORP.

Page: 1

MATICH CORPORATION
P.O. BOX 10
HIGHLAND, CA 92346

Cust/Job #:
18049-MERRILL & RIVERSIDE
000089 18049-LARCH & MERRILL
RIATFO

CUSTOMER INVOICE DATE TERMS
13068 108061 04/29/2019 10TH OF FOLLOWING MONTH

DESCRIPTION	QUANTITY	UM	PRICE	AMOUNT
Ticket Number 002-129652				
660-CW-4000 GREENBOOK	10.00	CY	80.00	800.00
FUEL SURCHARGE	1.00	LD	20.00	20.00
PREVAILING WAGE CHARGE	1.00	LD	220.00	220.00
ENVIRONMENTAL FEE	1.00	LD	40.00	40.00

TOTAL YARDS: 10.00 JOB TAX 83.70
 TOTAL 1163.70

TAXABLE AMOUNT 1,080.00
 EXEMPT AMOUNT 0.00
 SALES TAX 83.70
 INVOICE TOTAL 1,163.70



RANCHO READY MIX PRODUCTS, L.P.

Control Number: **588968**

150 SOUTH RANCHO AVENUE COLTON, CA 92324-3841

TEL (951) 225-5574

2825 LAKE STREET LAKEVIEW MORE, CA 92530

TEL (951) 674-0988

361 W. 4TH STREET BEAUMONT, CA 92226
TEL (951) 845-5511

WEIGHMASTER CERTIFICATE

X **MARY RICHARDSON**
DEPUTY - SIGNATURE

THIS IS TO CERTIFY that the following described commodity was weighed, measured, or counted by a weighmaster, whose signature is on this certificate, who is recognized authority of accuracy, as prescribed by chapter 7 (commencing with Section 12700) of Division 5 of the California Business and Professions Code, administered by the Division of Measurement Standards of the California Department of Food and Agriculture.

CONCRETE IS A PERISHABLE COMMODITY AND BECOMES THE PROPERTY OF THE PURCHASER UPON LOADING OF THE TRUCK. Any changes or cancellation of the ordered instructions must be telephoned to the plant before loading begins. If necessary to institute legal proceedings for the collection of payment for this material, the buyer agrees to pay all court costs of such suit and such attorney fees as the court may deem just and reasonable. NO DISCOUNTS will be allowed and INTEREST will be charged on all accounts not paid by the 10TH OF THE MONTH.

CONCRETE IS A NATURAL PRODUCT therefore we cannot be responsible for variations in color or surface discoloration caused by variations in finishing techniques. We also cannot be responsible for customer supplied mix designs.

WARNING - CONCRETE in a plastic state can be **IRRITATING TO THE SKIN AND EYES.** Concrete contains Portland Cement. Wear protective clothing and eyewear such as rubber boots, gloves, and safety glasses. Avoid contact with eyes and skin. **PROLONGED CONTACT MAY CAUSE BURNS.** In case of contact flush thoroughly with water. If irritation persists, get medical attention. **KEEP PLASTIC CONCRETE AWAY FROM THE CHILDREN.**

UNLOADING RELEASE

In consideration of RANCHO READY MIX PRODUCTS, L.P., hereinafter referred to as Material Dealer, delivering the purchased material to a place designated by the undersigned, the undersigned hereby releases and agrees to indemnify and hold harmless said Material Dealer, their Agents, employees and drivers from all liability or claims for damages done by it or them, to sidewalks, driveways, roadway property and all other real and personal property adjacent thereto, as a result of the movement of said Material Dealer's vehicles or employees upon or about such property. This release is intended to, and does cover all movements of all vehicles of said Material Dealer, while being used in delivering and unloading such purchased material at the location indicated below, from the time such vehicles leave the curb line to enter upon the property described below until their return to such curb line, regardless of the number and/or dates of such deliveries or movements. Claims for storage will only be allowed at the time the material is delivered.

Plant Name: _____

PORTLAND CEMENT ASSOCIATION CONTRACTION JOINT RECOMMENDATIONS: 4" THICK FLATWORK, PEA GRAVEL MIXES 8" X 8" MIXES 10" X 10" Minimum spacing for rebar shall be 1 to 1.5 length to width ratio) with joint depths of 1". Isolation joints to all other structures are highly recommended. Call more information or visit website at www.cement.org

TO JOB	ARRIVE	START	END	STAND BY	LEAVE	PLANT	TICKET #
019	090	091	1017				
DATE	TIME	PLANT #	ORDER #	CUST #	JOB #	ZONE	PROG #
29-Apr-15	09:09	002	33351	12058	18045	0	180132
SOLD TO			TRUCK #	LICENSE	NAME		LOAD #
				531152	TORRES, SPARTEL		1

JOB ADDRESS: **MATCH CORPORATION**
 INSTRUCTIONS: _____

JOB ADDRESS: **LARCH & MERRILL**
 RIALTO

JOB TIME: **SLUMP** USAGE: **MAP PAGE**

BATCH WAITER: **FREE MOISTURE** MAX WATER: **37%** WATER ADDED: **10**

TOTAL ORDERED	TOTAL SHIPPED	THIS TICKET	PRODUCT CODE	PRODUCT DESCRIPTION	UNITS	UNDERPRICE	EXTENSION
10.00	10.00	10.00	4000	GREENBOOK	CY		
1.00			09019	PREWALL LINE WASTE CHARGE	LD		
1.00			FSC	FUEL BURNING CHARGE	LD		
1.00							

CUSTOMER ASSUMES RESPONSIBILITIES FOR WATER ADDED BEYOND DESIGNED SLUMP. NOTICE: Excessive water is detrimental to concrete performance.

SUBTOTAL	
TAX	
TOTAL	
PREV. BAL.	
SUBTOTAL	
STAND BY	
TOTAL	

Jordan

CUSTOMER COPY



CCO No. 2, Item
16

August 5, 2019

Willdan Engineering
13191 Crossroads Parkway North, Suite 405
Industry, CA 91746

Attn: Barry Knutson, Construction Manager

Re: 2017/18 Annual Street Overlay Project, City Project Number. 180804
Change Order Request 7.12 – Hit Unmarked Water Valve, Standby for Repair

Dear Barry:

Matich Corporation respectfully submits this correspondence as a change order request for crew standby while City water operator identified and repaired an unmarked water valve on the southeast corner of Cedar and Merrill. During intersection re-construction, an unmarked water valve was hit by equipment performing the work. All activity was required to standby until such time as Veolia could identify and repair the unmarked water valve. Matich was directed to standby by the City. Please prepare a contract change order in the amount of \$2,386.13 for this work performed as directed.

Please do not hesitate to contact me with questions.

Respectfully,

Matich Corporation

A handwritten signature in black ink, appearing to read 'J. Reade', is written over the printed name.

by Jake Reade

Copy: File

Bcc:

Attachments:

DAILY EXTRA WORK REPORT

City Of Rialto	Contract: 180804	Change Order 100
Contractor Job: 18-049 - 2017/18 Annual Street Overlay Project		Billing Number 14.0
Work Performed By: Match Corporation		Report Date 5/21/2019
Description of Work: Hit Unmarked Water Valve On S/E Corner Of Cedar & Merrill. Stanby For Veolia To Identify & Repair		Perform Date 5/21/2019

Labor Charges									Labor Charges	
Craft/Level	Employee Name	RT Hrs	OT Hrs	Subs Units	RT Rate	OT Rate	Subs Rate	Extended	RT Labor	
L01	OE OF8	RF Del Toro	1.50		83.340			125.01		1,694.11
L02	OE OG8	R Kelso	1.50		81.110			121.67	OT Labor	0.00
L03	OE OG8	JA Lamas	1.50		81.110			121.67		
L04	OE OG8	R Sorbel	1.50		81.110			121.67	Subtotal Labor	1,694.11
L05	OEAP OA4	W Rahn	1.50		67.630			101.45	Subsistence	0.00
L06	OE OG8	N Brady	1.50		81.110			121.67	Other Expenses	0.00
L07	LBR LG4	R Arellano	1.50		63.600			95.40	MU 20.00%	338.82
L08	LBR LG4	J White	4.00		63.600			254.40	Labor Total	2,032.93
L09	LBR LG4	N Hernandez	4.00		63.600			254.40		
L10	LBR LG4	CT Morgan	1.50		63.600			95.40	Equipment Charges	
L11	LBR LG3	C Granados Gudino	1.50		61.870			92.81	Subtotal	294.76
L12	LBR LG2	M Ramirez, Jr.	1.50		61.250			91.88	MU 15.00%	44.21
L13	TMS TG5	E Forsythe	1.50		64.450			96.68	Equipment Total	338.97

Equipment Charges												Material Charges	
Equipment ID	Class	Make	Model	A1	A2	RT Hrs	OT Hrs	RT Rate	OT Rate	Delay Factor	Extended		
E01	7271	TRUCK	T&TT			4.00		38.380			153.52		
E02	21070	AIRCP	PORT		025-045	4.00		35.310			141.24		

	Activity Total 2,371.90
	Bill Surcharge
	Bonding 0.60% 14.23
	Work Total 2,386.13
	Bill Subtotal 2,386.13

For Owner/Resident Engineer's Use Only				Accepted:	
<input type="checkbox"/> New Bill	<input type="checkbox"/> Approved for Payment	Date of Action:	<input type="checkbox"/> Resubmittal	<input type="checkbox"/> Returned for Correction	Date Received:
				Customer:	Date:
				Contractor:	Date: 5/30/19
					Bill Total + 2,386.13



CCO No. 2, Item
No. 17

August 5, 2019

Willdan Engineering
13191 Crossroads Parkway North, Suite 405
Industry, CA 91746

Attn: Barry Knutson, Construction Manager

Re: 2017/18 Annual Street Overlay Project, City Project Number. 180804
Change Order Request 7.13 – Standby for Unsuitable Subgrade Decision from City

Dear Barry:

Matich Corporation respectfully submits this correspondence as a change order request for crew standby while City staff addressed unsuitable subgrade on the south side of Valley Boulevard east of Riverside Avenue. During removal and replacement of existing pavement section on the south side of Valley Boulevard east of Riverside Avenue, unsuitable subgrade appeared and extended below the curb and gutter. Matich was directed by the City to standby while the subgrade failure was investigated and final direction prepared. The subgrade was then repaired as directed, and final asphalt paving placed over the top of it. Please prepare a contract change order in the amount of \$16,547.56 for this standby and work performed as directed.

Please do not hesitate to contact me with questions.

Respectfully,

Matich Corporation

A handwritten signature in black ink, appearing to read 'Jake Reade', is written over a white background.

by Jake Reade

Copy: File

Bcc:

Attachments:

DAILY EXTRA WORK REPORT

City Of Rialto	Contract: 180804	Change Order 100
Contractor Job: 18-049 - 2017/18 Annual Street Overlay Project		Billing Number 15.0
Work Performed By: Matich Corporation		Report Date 6/10/2019
Description of Work: Standby For Decision On Unsuitable Subgrade , Then Repair		Perform Date 6/06/2019

Labor Charges								
Craft/Level	Employee Name	RT Hrs	OT Hrs	Subs Units	RT Rate	OT Rate	Subs Rate	Extended
L01	OE OF8	RF Del Toro	2.00		83.340			166.68
L02	OE OG8	R Kelso	2.00		81.110			162.22
L03	OE OG8	JA Lamas	2.00		81.110			162.22
L04	LBR LG2	J Cariota	2.00		61.250			122.50
L05	LBR LG4	M Carranza	2.00	0.50	63.600	103.070		178.74
L06	LBR LG4	JM Diaz	2.00		63.600			127.20
L07	LBR LG4	N Hernandez	2.00		63.600			127.20
L08	LBR LG2	W Lopez	2.00		61.250			122.50
L09	LBR LG4	CT Morgan	2.00	0.50	63.600	103.070		178.74
L10	LBR LG2	M Ramirez, Jr.	2.00		61.250			122.50
L11	LBR LG4	J White	2.00		63.600			127.20
L12	TMS TG5	C Wells	2.00		64.450			128.90
L13	TMS TG6	T Hoesman	2.00		64.480			128.96
L14	TMS TG6	O Burgess	2.00		64.480			128.96

Labor Charges	
RT Labor	1,881.44
OT Labor	103.08
Subtotal Labor	1,984.52
Subsistence	0.00
Other Expenses	0.00
MU 20.00%	396.90
Labor Total	2,381.42

Equipment Charges											
Equipment ID	Class	Make	Model	A1	A2	RT Hrs	OT Hrs	RT Rate	OT Rate	Delay Factor	Extended
E01	7255	TRUCK T&TT	06-12			2.00		29.600			59.20
E02	7263	TRUCK T&TT	06-12			2.00		29.600			59.20
E03	14141	LDRRT DEER	210LJ			2.00		43.290			86.58
E04	14134	LDRRT DEER	210LJB			2.00		50.050			100.10
E05	7278	TRUCK T&TT	12-20			2.00		38.380			76.76
E06	7271	TRUCK T&TT	12-20			2.00		38.380			76.76
E07	6070	TRUCK T&TT	36-48			2.00		61.920			123.84
E08	21070	AIRCP PORT	025-045			2.00		35.310			70.62
E09	3203	TRUON TRUN	4AXL			2.00		78.510			157.02
E10	3216	TRUON TRUN	4AXL			2.00		78.510			157.02

Equipment Charges	
Subtotal	967.10
MU 15.00%	145.07
Equipment Total	1,112.17

Material Charges	
Subtotal	3,190.00
MU 15.00%	478.50
Material Total	3,668.50
Activity Total	7,162.09

Material/Specialist Work/Lump Sum or Unit Price Payment						
Number	Date	Vendor Name and Description	Units	Unit Price	Extended	
M01	6/06/2019	Roger Wood Transportation, LLC. / 11 Strong-Arms	22.000 HR	95.00000	2,090.00	
M02	6/06/2019	Pavement Recycling Systems / Roadtec 600	2.000 HR	550.00000	1,100.00	
						Bill Subtotal 7,205.06

Bill Surcharge		
Bonding 0.60%		42.97
Work Total		7,205.06

For Owner/Resident Engineer's Use Only			
<input type="checkbox"/> New Bill	<input type="checkbox"/> Approved for Payment	Date of Action:	
<input type="checkbox"/> Resubmittal	<input type="checkbox"/> Returned for Correction	Date Received:	

Accepted:	
Customer:	Date: 6/20/19
Contractor:	Date: 6/20/19

Bill Total +	7,205.06
---------------------	-----------------

EXTRA WORK REPORT

CHANGE ORDER NUMBER _____

JOB NUMBER 18-049

WORK PERFORMED BY Matich Corp

DATE PERFORMED 6/6/19

DESCRIPTION OF WORK Standby for decision on unsuitable subgrade, then repair

DATE OF REPORT 6/10/19

EQUIPMENT

EQP. NO.	MAKE	MODEL	HOURS	RATE	AMOUNT
7-255	Ford	F-250	2		
7-263	Ford	F-250	2		
4-141	J.D.	Skip	2		
4-134	J.D.	Skip	2		
7-278	Ford	F-550	2		
7-271	Ford	F-550	2		
6070	Pete	wtr trk	2		
21-070	Compressor		2		
				SUBTOTAL	
				MARK-UP	
				TOTAL (A)	

LABOR

CRAFT	INT	NAME	REG	HOURS		EXTENDED TOTAL
				RATE	DIT	
OF-8	R	Del Toro	2			
0e-8	R	Kelso	2			
0e-8	J	Lamas	2			
L-2	J	Carriota	2			
L-4	M	Carranza	2		.5	
L-4	J	Diaz	2			
L-4	N	Hernandez	2			
L-2	W	Lopez	2			
L-4	C	Morgan	2		.5	
L-2	M	Ramirez	2			
L-4	J	White	2			
T-5	C	Wells	2			
				SUBTOTAL		
				LBR BURDEN		
				SUBSISTENCE		
				LBR MARK-UP		
				TOTAL (B)		

*13 TRUCKS TOTAL!
11 - ROGEE WOODS
2 - MATICH

MATERIAL and/or WORK done by specialists or LUMP SUM or UNIT PRICE PAYMENTS:

VENDOR	INVOICE NO.	DATE	DESCRIPTION	UNITS	UNIT COST OR NET PAY	EXTENDED TOTAL
AC Byers / Woods		6/6	13 - Strong arms - Standby*	26 hrs total		
Pavement Recycling		6/6	Roadtec 600-Mill	2 hrs		
				SUBTOTAL		
				MARK-UP		
				TOTAL (A)		

TOTAL (A + B + C)

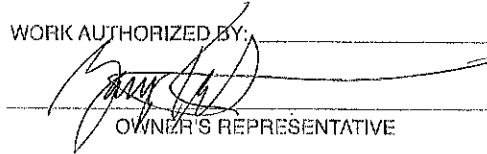
WORK AUTHORIZED BY: 
OWNER'S REPRESENTATIVE

MATICH'S REPRESENTATIVE

OFFICE USE ONLY

Report must be kept current
available for field inspection
at all times during the day.

MATICH TRUCK DRIVER'S DAILY REPORT

MS (Main Shop) 3231 E. 3rd St., San Bernardino, CA 92406 CHP (Cabazon Hot Plant) 13984 Apache Trail, Cabazon, CA 92230
LHP (Lytle Creek Hot Plant) 3221 N. Riverside Ave., Bakersfield, CA 92376 RHP (Redlands Hot Plant) 8397 Alabama St., Redlands, CA 92373

DRIVER'S DAILY LOG
(ONE CALENDAR DAY - 24 HOURS)

EQUIPMENT
BASED AT:

Rialto

EMPLOYEE NAME

Tracy Rosen

EMP. # 7264

DATE

6/6/19

TRUCK # 3203

TRAILER # N/A

TRAILER #

LINE	TICKET # (OR LOAD)	JOB # / CONTRACTOR / LOCATION OF DROP	LOADING		UNLOADING		DELAYS		TONS YARDS	TYPE MATERIAL	TIME		JOB #	RATE	C/C	O/L # EO	USED ONLY W/FLIGHT BOOK RECAP DAY NO.
			ARRIVED	LEFT	ARRIVED	LEFT	BEG.	END			ST.	O.T.					
1	MAINT.	Rialto Pro trip	5:23	5:40							1/4		B57B5				
2			6:00	6:05	6:15	6:20					7		B049		U05-3		
3			6:40	6:56	7:10	7:15											
4			7:35	7:57	8:15	8:22											
5			8:40	9:13	9:35	9:45											
6			10:00	10:08	10:35	10:40											
7			11:00	11:50	12:15	12:20											
8		had air leak fixed at the shop									1/4		B57B-2				
9		fuel	1:05	1:15							1/2		B57B-5				
10		post trip	1:15	1:30							8						

NOTE: DELAY TIME CHARGEABLE TO CUSTOMER SHOULD BE FULLY EXPLAINED ON DELIVERY TICKETS.

REASON FOR DELAY: (WRITE IN CORRESPONDING LINE NUMBER)

- 1: OFF DUTY
- 2: DRIVING
- 3: ON DUTY (NOT DRIVING)

MID-NIGHT	1	2	3	4	5	6	7	8	9	10	11	NOON	1	2	3	4	5	6	7	8	9	10	11	TOTAL HOURS

REMARKS OR DELAYS

MID-NIGHT	1	2	3	4	5	6	7	8	9	10	11	NOON	1	2	3	4	5	6	7	8	9	10	11

TIME STARTED 5:25 AM FINISHED 1:30 PM

TOTAL TIME ELAPSED 8

UNCL FROM _____ TO _____

STRAIGHT TIME 8

TOTAL TIME WORKED _____

OVERTIME _____

ORDER FROM PH PRINTING (909) 387-0717

SIGNATURE

[Signature]

MUST BE SIGNED DAILY. Certify these entries are true and correct.

ODOMETER START 5807812

STATE LINE 329805

STATE LINE 137

FINISH _____

TOTAL MILEAGE TODAY 137

Were you INJURED on the job? Yes No

If yes, have you filed injury report and notified your supervisor? Yes No

Did you have an ACCIDENT today? Yes No

(If YES, have you filed an Accident Report, AND notified your immediate supervisor?)

THIS IS YOUR TIME SHEET. IT MUST BE TURNED IN DAILY. YOUR PAY IS BASED ON THIS REPORT. NO TIME WILL BE PAID UNLESS IT IS ACCOUNTED FOR ON THIS FORM.

APPROVED BY _____ Form #1382

POSTED

**NON-NEGOTIABLE BILL-OF-LADING
AND TRANSPORTATION AGREEMENT**

BILL NO.

DATE
6-19

A - 3334853

PRINCIPAL CARRIER
ROGERWOOD

ADDRESS

CITY/STATE/ZIP

PH

JOB #

ROGERWOOD

BROKER #

702

TRUCK #

9901

TRAILER #

302037

UNDERLYING CARRIER (IF ANY)

James TRACKING

PH

SHIPPER

MATICH

RECEIVER

LANFILL

ADDRESS

Rivalls

ADDRESS

CITY/STATE/ZIP

DEPTLANDS

POINT OF ORIGIN

POINT OF DESTINATION

EQUIPMENT TYPE

- 10-WHEELER
- SUPER-10
- STRONG ARM

- SUPER TAG
- TRANSFER
- DBL BOTTOMS
- SEMIBOTTOM

- END DUMP
- SIDE DUMP
- TRUCK & PUP
- WATER TRUCK

- FLAT BED
- MIXER
- OTHER

HOURLY TONNAGE PER LOAD

RATE @ \$95.25

TAG NO.	WEIGHT	COMMODITY	LOADING		UNLOADING		STANDBY TIME	BREAKDOWN OR REASON FOR DELAY
			ARRIVE	DEPART	ARRIVE	DEPART		
1	700 MV	GRA	615	622	652	655		
2			718	728	755	800		
3	18-049		920	930	905	905		loads
4	Matich Repair		920	950	1015	1019		
5			1040	1140	1205	1210		
6								
7								
8	605-3							
9								
10								
11								
12		pumping areas/standby						
13								
14								
15								
	REPORTING TIME	ENDING TIME	TOTAL TIME	DEDUCTIBLE TIME	NET TIME	TOTAL TONS	ACCESSORIAL OTHER	TOTAL CHARGES
	STARTING TIME LAST TRIP	ARRIVAL TIME AT DUMP LAST TRIP	END LOADING LAST TRIP	RUNNING TIME LAST TRIP				
	615	1245	65	8	65			

SUBJECT TO TERMS AND CONDITIONS ON REVERSE SIDE

DRIVER SIGNATURE
Dose AQUIRRE

SHIPPER/RECEIVER (AGENT OR DEBITOR) SIGNATURE
DeWalt 7050 JOB

NON-NEGOTIABLE BILL OF LADING AND TRANSPORTATION AGREEMENT

BILL NO.

PRINCIPAL CARRIER

Rogerwood

DATE
6-6-19

A - 3334928

ADDRESS

Fon town

PH:

JOB #

BROKER #
TRUCK #
TRAILER #
CA #

Rogerwood
719-1
991842
302032

UNDERLYING CARRIER (IF ANY)

Chinas Trucking

PH

SHIPPER

Martich

RECEIVER

Loadfill

ADDRESS

ADDRESS

CITY/STATE/ZIP

CITY/STATE/ZIP

POINT OF ORIGIN

Balto

POINT OF DESTINATION

Roadroads

EQUIPMENT TYPE

- 10-WHEELER
- SUPER-10
- STRONG-ARM

- SUPER TAG
- TRANSFER
- DBL. BOTTOMS
- SEMI-BOTTOM
- END DUMP
- SIDE DUMP
- TRUCK & PUP
- WATER TRUCK

- FLAT BED
- MIXER
- OTHER

- HOURLY
 - TONNAGE
 - PER LOAD
- RATE @ \$ 95

TAG NO.	WEIGHT	COMMODITY	LOADING		UNLOADING		STANDEY TIME	BREAKDOWN OR REASON FOR DELAY
			ARRIVE	DEPART	ARRIVE	DEPART		
1		Gravel	6:00	6:30	6:55	7:05		
2		Gravel	7:02	7:45	8:02	8:05		
3		Gravel	8:05	8:50	9:13	9:18		
4		Gravel	9:15	9:55	10:15	10:20		
5		Gravel	10:20	11:50	12:15	12:20		
6		Gravel	11:50	12:15	12:15	12:20		
7								
8								
9								
10								
11								
12								
13								
14								
15								

5 Loads

REPORTING TIME	ENDING TIME	TOTAL TIME	DEDUCTIBLE TIME	NET TIME	TOTAL TONS	ACCESSORIAL OTHER
6:15	12:45	6:30				
START DRIVING TIME LAST TRIP	ARRIVAL TIME AT DUMP LAST TRIP	END LOADING LAST TRIP	RUNNING TIME LAST TRIP			

SUBJECT TO TERMS AND CONDITIONS ON REVERSE SIDE

TOTAL CHARGES

Alfredo Ramirez DRIVER SIGNATURE

DE NORA 7055 JOB SHIPPER/RECEIVER (AGENT OR DEBITOR) SIGNATURE

NON-NEGOTIABLE BILL OF LADING AND TRANSPORTATION AGREEMENT

BILL NO.

PRINCIPAL CARRIER Roger Wood Transport DATE 6-6-19

A - 4955102

ADDRESS P.O. Box 310188

JOB #

CITY/STATE/ZIP Fontana, CA 92331

BROKER # RWT

UNDERLYING CARRIER (IF ANY) A.B.T.

TRUCK # 517

ADDRESS 9145 Highland Ave POC 57001

TRAILER #

SHIPPER Matick

RECEIVER

Mattick Rodlands Dump

ADDRESS

ADDRESS

CITY/STATE/ZIP

CITY/STATE/ZIP

POINT OF ORIGIN

Vallejo, CA Riverside, Rodlands

POINT OF DESTINATION

2151 Nevada st, Rodlands

EQUIPMENT TYPE

- 10-WHEELER
- SUPER-10
- STRONGARM

- SUPER TAG
- TRANSFER
- DBL. BOTTOMS
- SEM-BOTTOM
- END DUMP
- SIDE DUMP
- TRUCK & PUP
- WATER TRUCK
- FLAT BED
- MIXER
- SWEEPER
- OTHER

- HOURLY
 - TONNAGE
 - PER LOAD
- RATE @ \$95.00

TAG NO	WEIGHT	COMMODITY	LOADING		UNLOADING		STANDBY TIME	BREAKDOWN OR REASON FOR DELAY		
			ARRIVE	DEPART	ARRIVE	DEPART				
1		Gravels	608	615	637	647				
2			702	711	732	741				
3			801	822	849	855				
4			920	925	959	1006				
5			1027	1145	1155	1236				
6				1225	1240					
7										
8										
9										
10										
11										
12										
13										
14										
15										
REPORTING TIME			6:10	ENDING TIME		1240	TOTAL TIME		6.5	
START DRIVING TIME LAST TRIP			ARRIVAL TIME AT QUART LAST TRIP			END LOADING TIME LAST TRIP			RUNNING TIME LAST TRIP	
TOTAL TONS			NET TIME			TOTAL TONS			ACCESSORIAL OTHER	
TOTAL CHARGES			SUBJECT TO TERMS AND CONDITIONS ON REVERSE SIDE			TOTAL CHARGES				

Dem7 DRIVER SIGNATURE

Dem7 SHIPPER/RECEIVER (AGENT OR DEBITOR) SIGNATURE

JOB

**NON-NEGOTIABLE BILL-OF-LADING
AND TRANSPORTATION AGREEMENT**

BILL NO.

DATE
5-6-19

A - 3334728

JOB #

BROKER #

TRUCK #

TRAILER #

CA #

PRINCIPAL CARRIER
ROBEK WOOD TRASF
ADDRESS
PO BOX 31018K
CITY/STATE/ZIP
FOXTAUA
PH.

UNDERLYING CARRIER
CAUWAS TRUCK
ADDRESS
PH.

SHIPPER
MATCH

RECEIVER
LAUD FIE

ADDRESS

ADDRESS

CITY/STATE/ZIP

CITY/STATE/ZIP

POINT OF ORIGIN

POINT OF DESTINATION

~~FOXTAUA~~ ROX CAUWAS

EQUIPMENT TYPE
 10-WHEELER
 SUPER-10
 STRONG ARM

SUPER TAG
 TRANSFER
 DBL. BOTTOMS
 SEMI-BOTTOM

END DUMP
 SIDE DUMP
 TRUCK & PUP
 WATER TRUCK

FLAT BED
 MIXER
 OTHER

HOURLY TONNAGE PER LOAD
RATE @ \$ 0.75

TAG NO.	WEIGHT	COMMODITY	LOADING		UNLOADING		STANDBY TIME	BREAKDOWN OR REASON FOR DELAY
			ARRIVE	DEPART	ARRIVE	DEPART		
1	LOAN	CRUMBLES	6:00	6:30	6:57	7:00		
2	LOAN	CRUMBLES	7:25	7:45	8:05	8:07		
3	LOAN	CRUMBLES	8:22	8:50	9:15	9:16		
4	LOAN	CRUMBLES	9:10	9:30	10:00	10:27		
5	LOAN	CRUMBLES	10:05	12:00				
6								
7								
8								
9								
10								
11								
12								
13								
14								
15								

REPORTING TIME	ENDING TIME	TOTAL TIME	DEDUCTIBLE TIME	NET TIME	TOTAL TONS	ACCESSORIAL OTHER	TOTAL CHARGES
6:00	1:07	6:06					

**SUBJECT TO TERMS AND
CONDITIONS ON REVERSE SIDE**

TOTAL CHARGES

DRIVER SIGNATURE _____ SHIPPER/RECEIVER (AGENT OR DEBITOR) SIGNATURE _____
JOB 7055

NON-NEGOTIABLE BILL OF LADING AND TRANSPORTATION AGREEMENT

BILL NO.

DATE
6/16/19

A - 3656551

PRINCIPAL CARRIER *Roger Wood*
ADDRESS *P.O. Box 310*

CITY/STATE/ZIP *Fontana, CA* PH.

UNDERLYING CARRIER (IF ANY) *As'a Mendoza Trucking*
ADDRESS *Fontana, CA* PH.

SHIPPER *PRSI / Matilda* RECEIVER *Lanefill*

ADDRESS *Riverview Ave + valley* ADDRESS *Nevada ST. 2151*
CITY/STATE/ZIP *Rialto, CA* CITY/STATE/ZIP *Redlands, CA*
POINT OF ORIGIN POINT OF DESTINATION

EQUIPMENT TYPE
 SUPER TAG
 10-WHEELER
 SUPER-10
 STRONG ARM
 END DUMP
 SIDE DUMP
 TRUCK & PUP
 WATER TRUCK
 FLAT BED
 MIXER
 SWEEPER
 OTHER
 HOURLY
 TONNAGE
 PER LOAD
 RATE @ \$ *95*

TAG NO.	WEIGHT	COMMODITY	LOADING		UNLOADING		STANDBY TIME	BREAKDOWN OR REASON FOR DELAY						
			ARRIVE	DEPART	ARRIVE	DEPART								
1		<i>Gravel</i>	<i>6:20</i>	<i>6:35</i>	<i>7:00</i>	<i>7:05</i>								
2		<i>Gravel</i>	<i>7:20</i>	<i>7:35</i>	<i>8:00</i>	<i>8:14</i>								
3		<i>Gravel</i>	<i>8:30</i>	<i>8:35</i>	<i>9:00</i>	<i>9:14</i>								
4		<i>Gravel</i>	<i>9:50</i>	<i>10:00</i>	<i>10:15</i>	<i>10:30</i>								
5		<i>Gravel</i>	<i>10:50</i>											
6														
7														
8														
9														
10														
11														
12														
13														
14														
15														
REPORTING TIME			ENDING TIME		TOTAL TIME		DEDUCTIBLE TIME		NET TIME		TOTAL TONS		ACCESSORIAL OTHER	
<i>6:20</i>			<i>1:00</i>		<i>6.7</i>									
START DRIVING TIME LAST TRIP			ARRIVAL TIME AT DUMP LAST TRIP			END LOADING LAST TRIP			RUNNING TIME LAST TRIP			TOTAL CHARGES		

510005

SUBJECT TO TERMS AND CONDITIONS ON REVERSE SIDE

DRIVER SIGNATURE *Harold Mendez* SHIPPER/RECEIVER (AGENT OR DEBITOR) SIGNATURE *Ally Belle Ross* JOB *7055*

**NON-NEGOTIABLE BILL-OF-LADING
AND TRANSPORTATION AGREEMENT**

BILL NO.

PRINCIPAL CARRIER

Woods

DATE

6-6-19

A - 4138254

ADDRESS

CITY/STATE/ZIP

PH

UNDERLYING CARRIER (IF ANY)

Banner Trucking

ADDRESS

PH

Medford, OR

JOB #

0328254

SHIPPER

RECEIVER

Medich

ADDRESS

ADDRESS

CITY/STATE/ZIP

CITY/STATE/ZIP

RAHO, CA

POINT OF ORIGIN

POINT OF DESTINATION

EQUIPMENT TYPE

- SUPER TAG
- 10-WHEELER
- SUPER-10
- STRONG ARM
- END DUMP
- TRANSFER
- DBL BOTTOMS
- SEMI-BOTTOM
- SIDE DUMP
- TRUCK & PUP
- WATER TRUCK
- FLAT BED
- MIXER
- SWEEPER
- OTHER

HOURLY TONNAGE PER LOAD

RATE @ \$ *95.00*

TAG NO.	WEIGHT	COMMODITY	LOADING		UNLOADING		STANDBY TIME	BREAKDOWN/REASON FOR DELAY
			ARRIVE	DEPART	ARRIVE	DEPART		
1	<i>7000</i>	<i>logs</i>	<i>6:30</i>	<i>6:45</i>	<i>7:12</i>	<i>7:20</i>		
2			<i>7:42</i>	<i>8:01</i>	<i>8:23</i>	<i>8:35</i>		
3			<i>8:55</i>	<i>9:18</i>	<i>9:32</i>	<i>9:40</i>		
4			<i>10:09</i>	<i>10:24</i>	<i>10:44</i>	<i>10:49</i>		
5								
6								
7								
8								
9								
10								
11								
12								
13								
14								
15								

REPORTING TIME	ENDING TIME	TOTAL TIME	DEDUCTIBLE TIME	NET TIME	TOTAL TONS	ACCESSORIAL OTHER	TOTAL CHARGES
<i>6:30</i>	<i>12:30</i>						<i>570.00</i>
START DRIVING TIME LAST TRIP	ARRIVAL TIME AT DUMP LAST TRIP	END LOADING LAST TRIP	RUNNING TIME LAST TRIP	SUBJECT TO TERMS AND CONDITIONS ON REVERSE SIDE			

DRIVER SIGNATURE *Shawna Johnson* SHIPPER/RECEIVER (AGENT OR DEBITOR) SIGNATURE *W. Wells* JOB

NON-NEGOTIABLE BILL-OF-LADING AND TRANSPORTATION AGREEMENT

BILL NO.

DATE 6/26/19

A - 2427704

PRINCIPAL CARRIER R.W. Transportation

JOB #

TRUCK # R.W. T-501

ADDRESS P.O. Box 310168

CITY/STATE/ZIP CA PH.

BROKER # R.W. T-501

UNDERLYING CARRIER (IF ANY) M. Weger Trucking LLC

ADDRESS 25973 Ave de Playa

TRAILER # 8892546

SHIPPER M.A.H.I.C.H. Cor

RECEIVER City of Redlands

ADDRESS Riverside Valley ave

ADDRESS California ave

CITY/STATE/ZIP Redlands

CITY/STATE/ZIP Redlands

EQUIPMENT TYPE SUPER TAG END DUMP FLAT BED HOURLY TONNAGE PER LOAD

10-WHEELER TRANSFER SIDE DUMP MIXER

SUPER-10 DBL BOTTOMS TRUCK & PUP OTHER

STRONG ARM SEMI-BOTTOM WATER TRUCK strong arm

TAG NO	WEIGHT	COMMODITY	LOADING		UNLOADING		STANDBY TIME	BREAKDOWN OR REASON FOR DELAY
			ARRIVE	DEPART	ARRIVE	DEPART		
1		Gravel	6:00	6:55	6:28	6:30		
2		Gravel	6:50	7:00	7:24	7:25		
3		Gravel	7:47	8:10	8:24	8:35		
4		Gravel	9:06	9:11	9:14	9:17		
5		Gravel	10:15	10:26	10:51	10:55		
6		Gravel	11:20					
7								
8								
9								
10								
11								
12								
13								
14								
15								

REPORTING TIME	ENDING TIME	TOTAL TIME	DEDUCTIBLE TIME	NET TIME	TOTAL TONS	ACCESSORIAL OTHER	TOTAL CHARGES
6:00	12:35	6:6	0	6:6			

START DRIVING TIME LAST TRIP

ARRIVAL TIME AT DUMP LAST TRIP

END LOADING LAST TRIP

RUNNING TIME LAST TRIP

SUBJECT TO TERMS AND CONDITIONS ON REVERSE SIDE

DRIVER SIGNATURE Magda Lovo Lopez JOB

SHIPPER/RECEIVER (AGENT OR DEBITOR) SIGNATURE R. W. T-501

**NON-NEGOTIABLE BILL-OF-LADING
AND TRANSPORTATION AGREEMENT**

BILL NO.

PRINCIPAL CARRIER

DLV

DATE

7.6.19

A - 2379352

ADDRESS

CITY/STATE/ZIP

PH.

JOB #
BROKER #
TRUCK #
TRAILER #
CA #

UNDERLYING CARRIER (IF ANY)
ADDRESS

EMP 7

PH.

509

SHIPPER

MATECS

RECEIVER

ADDRESS

ADDRESS

CITY/STATE/ZIP

CITY/STATE/ZIP

Valley Meadows

Food Mill

POINT OF DESTINATION

EQUIPMENT TYPE

- 10-WHEELER
- SUPER-10
- STRONG-ARM

- SUPER TAG
- TRANSFER
- DBL BOTTOMS
- SEMI-BOTTOM
- END DUMP
- SIDE DUMP
- TRUCK & PUP
- WATER TRUCK

- FLAT-BED
- MIXER
- OTHER

FLOURY TONNAGE PER LOAD
RATE @ \$ *95*

TAG NO.	WEIGHT	COMMODITY	LOADING		UNLOADING		STANDBY TIME	BREAKDOWN/REASON FOR DELAY
			ARRIVE	DEPART	ARRIVE	DEPART		
1		<i>Grnd</i>	<i>6:25</i>	<i>6:05</i>	<i>6:20</i>	<i>6:38</i>		
2		<i>=</i>	<i>6:58</i>	<i>7:07</i>	<i>7:25</i>	<i>7:34</i>		
3		<i>=</i>	<i>7:50</i>	<i>8:17</i>	<i>8:30</i>	<i>8:40</i>		
4		<i>=</i>	<i>5:44</i>	<i>5:52</i>	<i>5:57</i>	<i>6:05</i>		
5		<i>=</i>	<i>10:00</i>	<i>10:21</i>	<i>10:55</i>	<i>11:08</i>		
6		<i>=</i>	<i>11:18</i>	<i>11:18</i>	<i>11:18</i>	<i>11:18</i>		
7								
8								
9								
10								
11								
12								
13								
14								
15								
REPORTING TIME			ENDING TIME	TOTAL TIME	DEDUCTIBLE TIME	NET TIME	TOTAL TONS	ACCESSORIAL OTHER
<i>6:05</i>			<i>11:35</i>	<i>6:5</i>	<i>0</i>			
START/ENDING TIME LAST TRIP			ARRIVAL TIME AT DUMP LAST TRIP	END/LOADING LAST TRIP	RUNNING TIME LAST TRIP	TOTAL CHARGES		

5 TRUCKS

SUBJECT TO TERMS AND CONDITIONS ON REVERSE SIDE

DRIVER SIGNATURE

[Signature]

JOB

SHIPPER/RECEIVER (AGENT OR DEBITOR) SIGNATURE

NON-NEGOTIABLE BILL-OF-LADING AND TRANSPORTATION AGREEMENT

BILL NO.

PRINCIPAL CARRIER Roger Woodhouse DATE 6-06-2019

A - 2860965

ADDRESS P O Box 310188

JOB #
BROKER # Roger Wood
TRUCK # 537

CITY/STATE/ZIP Fontana CA 92331

UNDERLYING CARRIER RST TRUCKING

TRAILER # ⊕

ADDRESS 309 Caldera Street, CA 92570

CA # 321816

SHIPPER MATICH

RECEIVER MATICH

ADDRESS Riverside Valley Bv

ADDRESS

CITY/STATE/ZIP Rialto CA

CITY/STATE/ZIP

POINT OF ORIGIN

POINT OF DESTINATION

- EQUIPMENT TYPE
- 10-WHEELER
 - SUPER TAG
 - SUPER-10
 - STRONG ARM
 - TRANSFER
 - DBL BOTTOMS
 - SEMI-BOTTOM
 - END DUMP
 - SIDE DUMP
 - TRUCK & PUP
 - WATER TRUCK
 - FLAT BED
 - MIXER
 - OTHER
- HOURLY TONNAGE PER LOAD
- RATE @ \$ 95

TAG NO	WEIGHT	COMMODITY	LOADING		UNLOADING		STANDBY TIME	BREAKDOWN OR REASON FOR DELAY
			ARRIVE	DEPART	ARRIVE	DEPART		
1	LOAD	Grind	5:10	6:20	6:40	6:45		
2	LOAD	Grind	7:05	7:15	7:40	7:45		
3	LOAD	Grind	8:05	8:35	9:00	9:05		
4	LOAD	Grind	9:30	9:35	10:00	10:05		
5	LOAD	Grind	10:30	11:40	12:00	12:05		
6								
7								
8								
9								
10								
11								
12								
13								
14								
15								

REPORTING TIME	ENDING TIME	TOTAL TIME	DEDUCTIBLE TIME	NET TIME	TOTAL TONS	ACCESSORIAL OTHER	TOTAL CHARGES
START DRIVING TIME LAST TRIP: <u>6:16</u>	ARRIVAL TIME AT DUMP LAST TRIP: <u>12:40</u>	END LOADING LAST TRIP: <u>6:15</u>	RUNNING TIME LAST TRIP: <u>⊕</u>				

SUBJECT TO TERMS AND CONDITIONS ON REVERSE SIDE

DRIVER SIGNATURE Roger Woodhouse 6-06-2019 SHIPPER/RECEIVER (AGENT OR DEBTOR) SIGNATURE Carol 7055 JOB

**NON-NEGOTIABLE BILL-OF-LADING
AND TRANSPORTATION AGREEMENT**

BILL NO.

DATE
6-6-19

A - 3556337

PRINCIPAL CARRIER

Roos Woods

JOB #

ADDRESS

BROKER #

CITY/STATE/ZIP

TRUCK #

7

UNDERLYING CARRIER (IF ANY)

A 24 Meadows Trucking

TRAILER #

ADDRESS

Fontana CA

PH

Redlands Trucking

CA #

4152876

SHIPPER

Mitch Valley & Riverside

RECEIVER

Redlands Landfill

ADDRESS

Valley & Riverside

ADDRESS

815 Nevada

CITY/STATE/ZIP

Rialto CA

CITY/STATE/ZIP

Redlands, CA

POINT OF ORIGIN

POINT OF DESTINATION

EQUIPMENT TYPE

- 10-WHEELER
- SUPER-10
- STRONG ARM

- SUPER TAG
- TRANSFER
- DBL BOTTOMS
- SEM-BOTTOM

- END DUMP
- SIDE DUMP
- TRUCK & PUP
- WATER TRUCK

- FLAT BED
- MIXER
- SWEEPER
- OTHER

- HOURLY
- TONNAGE
- PERLOAD

RATE @ \$ 95.02

TAG NO	WEIGHT	COMMODITY	LOADING		UNLOADING		STANDBY TIME	BREAKDOWN OR REASON FOR DELAY
			ARRIVE	DEPART	ARRIVE	DEPART		
1		Grinds	6:35	6:40	7:05	7:13		
2		Grinds	7:21	7:48	8:12	8:17		
3		Grinds	8:35	9:10	9:30	9:37		
4		Grinds	10:00	10:07	10:25	10:32		
5		Grind	10:48	12:40				
6								
7								
8								
9								
10								
11								
12								
13								
14								
15								

(Handwritten circled text: "6V 1055")

REPORTING TIME	ENDING TIME	TOTAL TIME	DEDUCTIBLE TIME	NET TIME	TOTAL TONS	ACCESSORIAL OTHER	TOTAL CHARGES
6:25	1:10	6:9		6:9			
START DRIVING TIME LAST TRIP	ARRIVAL TIME AT DUMP LAST TRIP	END LOADING LAST TRIP	RUNNING TIME LAST TRIP	SUBJECT TO TERMS AND CONDITIONS ON REVERSE SIDE			

DRIVER SIGNATURE

SHIPPER/RECEIVER (AGENT OR DEBITOR) SIGNATURE

JOB

**NON-NEGOTIABLE BILL-OF-LADING
AND TRANSPORTATION AGREEMENT**

BILL NO.

PRINCIPAL CARRIER Rogers Woods

DATE 6/6/19

A - 8658338

ADDRESS _____ PH. _____

JOB # _____
BROKER # _____
TRUCK # _____

UNDERLYING CARRIER (IF ANY) CHW Mendosa

PH. _____

TRAILER # _____
CA# 514083

SHIPPER MA-TI CH

RECEIVER _____

ADDRESS Diversides Valley

ADDRESS _____

CITY/STATE/ZIP Plym, CA

CITY/STATE/ZIP _____

POINT OF ORIGIN _____

POINT OF DESTINATION _____

EQUIPMENT TYPE
 SUPER TAG END DUMP FLAT BED
 10-WHEELER TRANSFER SIDE DUMP MIXER
 SUPER-10 DBL BOTTOMS TRUCK & PUP SWEEPER
 STRONG ARM SEMI-BOTTOM WATER TRUCK OTHER _____

RATE @ \$ 95

HOURLY TONNAGE PER LOAD

TAG NO.	WEIGHT	COMMODITY	LOADING		UNLOADING		STANDBY TIME	BREAKDOWN OR REASON FOR DELAY
			ARRIVE	DEPART	ARRIVE	DEPART		
1	N/A	gravel	6:30	6:40	7:16	7:15		
2	N/A	gravel	7:40	7:52	8:20	8:27		
3	N/A	gravel	8:46	9:04	9:35	9:36		
4	N/A	gravel	10:00	10:15	10:35	10:40		
5	N/A	gravel	11:00					
6								
7								
8								
9								
10								
11								
12								
13								
14								
15								



REPORTING TIME	ENDING TIME	TOTAL TIME	DEDUCTIBLE TIME	NET TIME	TOTAL TONS	ACCESSORIAL OTHER	TOTAL CHARGES
6:30	1:15	6:47	0	6:47			
START DRIVING TIME LAST TRIP	ARRIVAL TIME AT DUMP LAST TRIP	END LOADING LAST TRIP	RUNNING TIME LAST TRIP				

DRIVER SIGNATURE CHW Mendosa SHIPPER/RECEIVER (AGENT OR DEBITOR) SIGNATURE _____

JOB # 735

SUBJECT TO TERMS AND CONDITIONS ON REVERSE SIDE

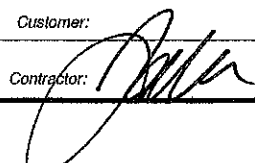
DAILY EXTRA WORK REPORT

City Of Rialto Contractor Job: 18-049 - 2017/18 Annual Street Overlay Project Work Performed By: Match Corporation Description of Work: Standby For Decision On Unsuitable Subgrade, Then Repair & Pave						Contract: 180804		Change Order 100 Billing Number 16.0 Report Date 6/10/2019 Perform Date 6/06/2019				
Labor Charges												
Craft/Level	Employee Name	RT Hrs	OT Hrs	Subs Units	RT Rate	OT Rate	Subs Rate	Extended				
L01	OE OF8	G Fonville, Jr	2.00		83.340			166.68	RT Labor	1,592.00		
L02	OE OG8	M Fonville	2.00		81.110			162.22	OT Labor	0.00		
L03	OE OG8	JL Lamas	2.00		81.110			162.22				
L04	OEAP OA4	C Lamas	2.00		67.630			135.26	Subtotal Labor	1,592.00		
L05	OE OG6	R Molina	2.00		80.990			161.98	Subsistence	0.00		
L06	OE OG6	A Corona	2.00		80.990			161.98	Other Expenses	0.00		
L07	OE OG6	J Fierro	2.00		80.990			161.98	MU 20.00%	318.40		
L08	LBR LG4	J Cortez	2.00		63.600			127.20	Labor Total	1,910.40		
L09	LBR LG4	N Gonzales	2.00		63.600			127.20				
L10	LBR LG4	B Ayon	2.00		63.600			127.20				
L11	LBRAP LA5	A Cortez	2.00		49.040			98.08				
Equipment Charges												
Equipment ID	Class	Make	Model	A1 A2	RT Hrs	OT Hrs	RT Rate	OT Rate	Delay Factor	Extended		
E01	15156	ASPAV	CAT	AP1055F	2.00		244.090			488.18		
E02	16127	ROVIB	CAT	CB434C	2.00		55.570			111.14		
E03	16130	ROLRT	CAT	PS360B	2.00		72.610			145.22		
E04	16121	ROVIB	CAT	8062	2.00		57.570			115.14		
E05	7253	TRUCK	T&TT	06-12	2.00		29.600			59.20		
E06	7246	TRUCK	T&TT	12-20	2.00		38.380			76.76		
Material/Specialist Work/Lump Sum or Unit Price Payment												
Number	Date	Vendor Name and Description				Units	Unit Price	Extended				
M01	6/06/2019	Match Corporation / 3/4" B PG 64-10 & Haul				98.520 TON	55.00000	5,418.60				
										Activity Total	9,286.78	
										Bill Surcharge		
										Bonding	0.60%	55.72
										Work Total	9,342.50	
										Bill Subtotal	9,342.50	
For Owner/Resident Engineer's Use Only <input type="checkbox"/> New Bill <input type="checkbox"/> Approved for Payment Date of Action: <input type="checkbox"/> Resubmittal <input type="checkbox"/> Returned for Correction Date Received:						Accepted: Customer: _____ Date: _____ Contractor:  Date: 		Bill Total + 9,342.50				

EXTRA WORK REPORT

CHANGE ORDER NUMBER _____

JOB NUMBER 18-049

WORK PERFORMED BY MATCH Corp

DATE PERFORMED 6-6-19

DESCRIPTION OF WORK
STANDBY for Decision on Unsuitable material Valley Blvd
AND Repair + Paul

DATE OF REPORT 6-10-19

EQUIPMENT

EQP. NO.	MAKE	MODEL	HOURS	RATE	AMOUNT
15156	Cat	AP1055	2		
16-127	Cat	CB534	2		
16-130	Cat	PS360	2		
16-121	Cat	PS360	2		
1253	FORD	F250	2		
1246	FORD	F-550	2		
				SUBTOTAL	
				MARK-UP	
				TOTAL (A)	

LABOR

CRAFT	NAME		REG	HOURS		EXTENDED TOTAL
	INT	LAST		RATE	OT	
OEB	G	Fonville JR	2			
OEB	M	Fonville	2			
OEB	JL	Lamas	2			
RAPPAP	C	Lamas	2			
OEB	R	Molina	2			
OEB	A	Correa	2			
OEB	J	Flevo	2			
L-4	J	Correa	2			
L-4	M	Gonzales	2			
L-4	B	Aron	2			
MPL	A	Cortez	2			
				SUBTOTAL		
				LBR BURDEN		
				SUBSISTENCE		
				LBR MARK-UP		
				TOTAL (B)		

MATERIAL and/or WORK done by specialists or LUMP SUM or UNIT PRICE PAYMENTS:

VENDOR	INVOICE NO.	DATE	DESCRIPTION	UNITS	UNIT COST OR NET PAY	EXTENDED TOTAL
<u>MATCH</u>		<u>6-6-19</u>	<u>AC</u>	<u>98.52</u>	<u>7.25</u>	
				SUBTOTAL		
				MARK-UP		
				TOTAL (A)		

WORK AUTHORIZED BY:

OFFICE USE ONLY

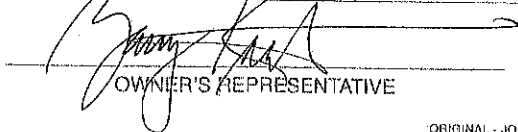
OWNER'S REPRESENTATIVE

MATCH'S REPRESENTATIVE

m 48-
H 57-

SUBTOTAL	
MARK-UP	
TOTAL (A)	
TOTAL (A + B + C)	



August 1, 2019

City PCO No. 17

Willdan Engineering
13191 Crossroads Parkway North, Suite 405
Industry, CA 91746

Attn: Barry Knutson, Construction Manager

Re: 2017/18 Annual Street Overlay Project, City Project Number. 180804
Change Order Request – Sign Posts and Striping Extra Work

Dear Barry:

Matich Corporation respectfully submits this correspondence as a change order request to furnish and install 3 sign posts where posts did not exist per the plans and construction note SA and perform additional striping removal as directed by the City on Rialto Avenue. The total amount to furnish and install the posts is \$412.50 (\$137.50 each), and the amount to remove the existing striping on Rialto Avenue is \$333.32. Please see the attached supporting documents. Please prepare a contract change order in the amount of \$745.82 for this work performed as directed.

Please do not hesitate to contact me with questions.

Respectfully,

Matich Corporation

A handwritten signature in black ink, appearing to read 'J. Reade', is written over the company name.

by Jake Reade

Copy: File

Bcc:

Attachments:

DAILY EXTRA WORK REPORT

Sub: CALSTRIPE Bill: 1.0 Job: 19006 \$275.47

Contract: **19-005**

Change Order **001**
 Billing Number **1.0**
 Report Date **7/31/2019**
 Perform Date **7/02/2019**

City Of Rialto
 Contractor Job: 19006 - 2017-2018 Annual Overlay Project
 Work Performed By: Cal Stripe, Inc. (For Match Corporation)
 Description of Work: Remove 2 Stops At Slurry Location

Labor Charges		Employee Name	RT Hrs	OT Hrs	Subs Units	RT Rate	OT Rate	Subs Rate	Extended
L01	LBR	M Haro	1.00			77.670			77.67
L02	LBRAP	J Aguayo	1.00			43.600			43.60

Equipment Charges		Class	Make	Model	A1	A2	RT Hrs	OT Hrs	RT Rate	OT Rate	Delay Factor	Extended
E01	20	STRIP	PYCO	P309			1.00		98.020			98.02
E02	20A	TRAF	FLAS	RM			1.00		0.940			0.94
E03	RE01	STREM	VAN	FR250			1.00		8.760			8.76

Labor Charges		RT Labor	121.27
		OT Labor	0.00
		Subtotal Labor	121.27
		Subsistence	0.00
		Other Expenses	0.00
		MU 25.00%	<u>30.32</u>
		Labor Total	151.59

Equipment Charges		Subtotal	107.72
		MU 15.00%	16.16
		Equipment Total	123.88

Material Charges		Activity Total	275.47
		Work Total	275.47
		Subcontract Markup	
		MU 10.00%	27.55
		Bill Subtotal	303.02

\$303.02 + 10% Markup = \$333.32

Cal Stripe, Inc.	Accepted:	Date:
	Customer:	Date:
	Contractor:	Date:
Bill Total +		303.02



CAL STRIPE INC.

2040 E. Steel Road
Colton, CA. 92324
Phone: (909) 884-7170
Fax: (909) 884-7106
Cell: (909) 206-7206
General Engineering Class A
Ca. Lic.# 685387
Signatory Laborers Union Local No.1184
DIR Registration #: 1000001100
ESTIMATOR: Adam Lippa

EXTRA WORK QUOTATION NO. 2 – Furnish & Install New Sign Posts

July 3, 2019

CAL STRIPE JOB No: 19006
PROJECT DESCRIPTION: 2017-2018 Annual Overlay
CONTRACT / PROJECT No: 19-005
PRIME CONTRACTOR NAME: Match
PRIME CONTRACTORS JOB NUMBER: 18-049

1. Cal Stripe Inc.'s subcontract proposal is good for 30 days only.
2. If this proposal is accepted, it is to be incorporated as an exhibit to the Contract or purchase order.
3. A signed purchase order, or subcontract is required prior to any work associated with this proposal.
4. Contractor to provide monthly progress payments for all completed work in accordance with the bid pricing schedule. Monthly progress payments must be received in full by Cal Stripe no later than 10 calendar days after the Contractor receives payment from Owner. Retention percentage on monthly progress payments to be no greater than the percentage retained by the Owner on its payments to the Contractor. If Owner reduces the retention percentages on payments to the Contractor, the Contractor shall likewise reduce the retention percentage on payments to Cal Stripe.
5. Full retention to be released no later than thirty (30) days after completion of Cal Stripe's extra work regardless of payment by the Owner
6. Any required Testing, Engineering, Design, Permits, Licenses or Applications, and the like to be provided by others.
7. Prices are based on Plans & Specifications available at bid time, including all addenda.
8. All changes to the original scope of work or proposed extra work must be directed by the Contractor in writing prior to Cal Stripe performing this work.
9. For the purpose of this Subcontract Quotation one (1) move-in is considered to be a period of consecutive eight (8) hour days of continuous work, not including weekends and holidays. Any discontinuities in this period, other than weekends and holidays, or for our own convenience, will be charged as an additional move-in at the Addition Move-in Charge as quoted herein.
10. Traffic control plans are not included.
11. If Contractor requires a Bond, the Prime Contractor shall pay for the cost of the bond.
12. Cal Stripe carries \$5,000,000.00 of insurance coverage only. Additional coverage's required by Prime to be paid by Prime Contractor.
13. Items or Processes Not Specifically Included Are Considered To Be Excluded.
14. The new sign posts must be completed in conjunction with original contracted sign scope of work, or an additional move in charge will apply.



August 8, 2019

Willdan Engineering
13191 Crossroads Parkway North, Suite 405
Industry, CA 91746

Attn: Barry Knutson, Construction Manager

Re: 2017/18 Annual Street Overlay Project, City Project Number. 180804
Change Order Request 10 – Install Homerun for Loops on Merrill at Riverside

Dear Barry:

Matich Corporation respectfully submits this correspondence as a change order request to install a homerun from the loops on Merrill Avenue eastbound at Riverside Avenue on Merrill Avenue to the controller as directed by the City. No conduit or pull boxes exist for these loops, therefore a homerun had to be cut to reach the controller cabinet. Please prepare a contract change order in the amount of \$1,104.27 for this standby and work performed as directed.

Please do not hesitate to contact me with questions.

Respectfully,

Matich Corporation

A handwritten signature in black ink, appearing to read 'J. Reade', is written over the company name.

by Jake Reade

Copy: File

Bcc:

Attachments:

DAILY EXTRA WORK REPORT

City Of Rialto	Contract: 180804	Change Order 100
Contractor Job: 18-049 - 2017/18 Annual Street Overlay Project		Billing Number 17.0
Work Performed By: Match Corporation		Report Date 8/08/2019
Description of Work: Install Home Run For Loops At Merrill And Riverside		Perform Date 6/25/2019

Subcontract/Specialist Work						
Number	Date	Vendor Name and Description	Units	Unit Price	Extended	
S01 19056	6/25/2019	Smithson Electric, Inc. / INSTALL HOME RUN FOR LOOPS AS DIRE	1.000 LS	1,045.41	1,045.41	

Labor Charges	
Equipment Charges	
Material Charges	
Subcontract Charges	
Subtotal	1,045.41
MU 5.00%	52.27
Subcontract Total	1,097.68
Activity Total	1,097.68
Bill Surcharge	
Bonding 0.60%	6.59
Work Total	1,104.27
Bill Subtotal	1,104.27

<p style="text-align: center;">For Owner/Resident Engineer's Use Only</p> <p> <input type="checkbox"/> New Bill <input type="checkbox"/> Approved for Payment Date of Action: _____ <input type="checkbox"/> Resubmittal <input type="checkbox"/> Returned for Correction Date Received: _____ </p>	<p>Accepted:</p> <p>Customer: _____ Date: _____</p> <p>Contractor: <i>[Signature]</i> Date: 8/8/19</p>	<p>Bill Total + 1,104.27</p>
---	---	-------------------------------------

SMITHSON ELECTRIC, INC.
Additional Work Authorization

Job Location: Riverside & Merrill
Working for: MATCH CORPORATION

DATE: 6/25/2019
CCO/Change Order: T & M
SEI Job #: 19056
Client Job #: 18-049

LABOR

EMPLOYEE NUMBER	EMPLOYEE NAME	CLASS	TOTAL HOURS			HOURLY RATE	HOURLY RATE	HOURLY RATE	AMOUNT
			ST	OT	DT				
1	106 REYES, RANDOLPH	ELECT - FMN	1.50			92.14	\$	-	\$ 138.21
2	111 RAYGOZA, JESUS	ELECT - JMN	1.50			83.02	\$	-	\$ 127.53
3	124 GARCIA, MATTHEW	ELECT - JMN	1.50			83.02	\$	-	\$ 127.53
4	124 VIERA, RICHARD	LABORER	1.50			49.91	\$	-	\$ 74.87
5						-	\$	-	\$ -
6						-	\$	-	\$ -
7						-	\$	-	\$ -
8						-	\$	-	\$ -
TOTALS			6			-	\$	-	\$ 488.14

RG Surcharge \$
OT Surcharge \$
Mark-up 20% \$ 93.63
TOTAL LABOR \$ 561.77

EQUIPMENT / RENTALS / SUBCONTRACTORS / OTHER (not labor or material)

SEI EQUIPMENT NUMBER/NAME	DESCRIPTION	CLASS	MAKE	CODE	QTY	UNIT RATE	UNIT	AMOUNT
1	Ford F450 Utility Truck	TRUCK	T&TT	12-20	1.5	38.38	HR	\$ 57.57
2	Ford F450 Utility Truck	TRUCK	T&TT	12-20	1.5	38.38	HR	\$ 57.57
3	Ford F450 SD Foreman Truck	TRUCK	T&TT	12-20	1.5	38.38	HR	\$ 57.57
4	Towable Air Compressor	AIRCP	PORT	004-016	1.5	18.54	HR	\$ 27.81
5	Equipment Trailer	TRAIL	LB-A	100	1.5	15.75	HR	\$ 23.63
6	MECO 60HP - Circle Saw	SAWCO	ABOP	45-65	1.5	20.72	HR	\$ 31.08
7	MECO 60HP - Flat Saw	SAWCO	ABOP	45-65	1.5	20.72	HR	\$ 31.08
8	Cratos SuperShot 60	SAWCO	ABOP	45-65	1.5	20.72	HR	\$ 31.08
9	Arrowboard	TRAF	FLAS	TM	1.5	3.43	HR	\$ 5.15
10	Arrowboard	TRAF	FLAS	TM	1.5	3.43	HR	\$ 5.15
11	GM/C C7500 Vacuum Truck	TRUCK	T&TT	36-48	1.5	61.92	HR	\$ 92.88
12								\$ -
TOTALS					16.5			\$ 420.56

Mark-up 15% \$ 63.08
TOTAL EQUIP \$ 483.64

MATERIAL

DESCRIPTION OF MATERIAL	VENDOR	INVOICE NUMBER	QTY	UNIT RATE	UNIT	AMOUNT
1						\$ -
2						\$ -
3						\$ -
4						\$ -
5						\$ -
6						\$ -

RECEIVED
MAY 1 2019

LABOR \$ 468.14
EQUIPMENT \$ 420.56
MATERIAL \$
GRAND TOTAL \$888.69

561.77 Orange County
483.64
1,045.41
8/8/19

Work: Installed advance deter loops EB. 150' Homerun.
Description:



July 1, 2019

Willdan Engineering
13191 Crossroads Parkway North, Suite 405
Industry, CA 91746

Attn: Barry Knutson, Construction Manager

Re: 2017/18 Annual Street Overlay Project, City Project Number. 180804
Change Order Request – Working Days

Dear Barry:

Matich Corporation respectfully submits this correspondence as a change order request for additional working days. The requested days are as follows:

1. Bid Schedule B, Item 23 “Install IISNS on Signal Mast Arm” – The initial submittal for the sign was made on February 8, 2019 and was returned on February 21, 2019 marked “revise and resubmit”. RFI number 2 was prepared on March 7, 2019 and addressed the issues involving the sign. The response from the City was received on March 14, 2019 and the re-submittal was forwarded on March 22, 2019. Approval from the City was received on May 21, 2019, 41 working days later. This is 21 working days longer than the 20 days shown allowed in the special provisions. 21 working days are requested for this sign.
2. Merrill Avenue and Rialto Avenue Construction – The City requested that Rialto Avenue be paved to finish surface for a car show to be held the weekend of June 8, 2019. Matich Corporation adjusted the schedule to accommodate this request however it affected the overlay of the remaining portion of Merrill Avenue which was moved to June 17 in order to accommodate Rialto Avenue. This move affected the overall schedule of the project as the majority of project striping and signage was on Merrill Avenue and could not be completed until the street was paved to finish, striping layout completed, loop installation, and utilities raised. 14 working days are requested for this change to the schedule.
3. Merrill Avenue Construction – While preparing traffic plans early in the project, the City and Matich Corporation discussed work in front of the school on Merrill Avenue. At that meeting we discussed the possibility of delaying the work immediately in front of the school until summer recess. It was agreed this would be the safest approach. Considering the volume of traffic during the morning drop off and afternoon pick up, work was scheduled to start after June 3, 2019. The final overlay on Merrill Avenue near the school was originally scheduled for May 13, 2019. This date was moved to June 3, 2019 (subsequently moved to June 17 per item 2 above), 15 working days later. 15 working days are requested for this change to the schedule.

Considering the items referenced above were for the most part constructed concurrently, Matich Corporation requests the preparation of a contract change order adding a total of 21 working days.

Please do not hesitate to contact me with questions.

Respectfully,

Matich Corporation

A handwritten signature in black ink, appearing to read "J. Reade", written in a cursive style.

by Jake Reade

Copy: File

Bcc:

Attachments: